



AGENDA
CUYAHOGA COUNTY PUBLIC WORKS, PROCUREMENT & CONTRACTING
COMMITTEE MEETING
WEDNESDAY, JULY 26, 2023
CUYAHOGA COUNTY ADMINISTRATIVE HEADQUARTERS
C. ELLEN CONNALLY COUNCIL CHAMBERS – 4TH FLOOR
10:00 AM

Committee Members:

Scott Tuma, Chair – District 4
Dale Miller, Vice Chair – District 2
Yvonne M. Conwell – District 7
Meredith M. Turner – District 9
Martin J. Sweeney – District 3

- 1. CALL TO ORDER**
- 2. ROLL CALL**
- 3. PUBLIC COMMENT**
- 4. APPROVAL OF MINUTES FROM THE JULY 12, 2023 MEETING [See page 4]**
- 5. MATTERS REFERRED TO COMMITTEE**
 - a) R2023-0209: A Resolution declaring that public convenience and welfare requires the resurfacing of Snow Road from Ridge Road to State Road in the City of Parma at a total estimated project cost of \$2,429,196.00; and finding that special assessments will neither be levied nor collected to pay for any part of the County's costs of said improvement; authorizing the County Executive to enter into an agreement of cooperation with City of Parma in connection with said project; and declaring the necessity that this Resolution become immediately effective. [See page 7]

- b) R2023-0210: A Resolution approving Right-of-Way Exhibits as set forth in Plat No. M-5052 for rehabilitation of North Marginal Road Connector from East 9th Street to East 55th Street in the City of Cleveland; authorizing the County Executive through the Department of Public Works to acquire said necessary Right-of-Way; and declaring the necessity that this Resolution become immediately effective.[See page 12]
- c) R2023-0211: A Resolution fixing the 2024 water, storm and sanitary sewer maintenance and/or sewerage treatment rates for County Sewer District Nos. 1, 1A, 2, 3, 5, 8, 9, 13, 14, 18, 20, 21, 22 and 24, in accordance with Ohio Revised Code Section 6117.02; and declaring the necessity that this Resolution become immediately effective.[See page 51]
- d) R2023-0212: A Resolution approving and confirming the 2024 water, storm and sanitary sewer maintenance and/or sewerage treatment assessments for County Sewer District Nos. 1, 1A, 2, 3, 5, 8, 9, 13, 14, 18, 20, 21, 22 and 24, in accordance with Ohio Revised Code Section 6117.02; and declaring the necessity that this Resolution become immediately effective.[See page 62]
- e) R2023-0213: A Resolution making an award on RQ12725 with Specialized Construction, Incorporated in the amount not-to-exceed \$1,082,130.86 for asphalt resurface preservation, crack sealing and striping for the 2023 Countywide Preventative Maintenance Program; authorizing the County Executive to execute Contract No. 3582 and all other documents consistent with said award and this Resolution; and declaring the necessity that this Resolution become immediately effective.[See page 70]
- f) R2023-0214: A Resolution making awards on RQ12381 with various engineering firms in the total amount not-to-exceed \$1,350,000.00 for general engineering services, commencing upon contract signature of all parties for a period of three (3) years; authorizing the County Executive to execute Contract Nos. 3585, 3586 & 3854 and all other documents consistent with said awards and this Resolution; and declaring the necessity that this Resolution become immediately effective:[See page 80]
- 1) Contract No. 3854 with Crawford, Murphy & Tilly, Inc. in the amount not-to-exceed \$450,000.00.
 - 2) Contract No. 3585 with Chagrin Valley Engineering, Ltd. in the amount not-to-exceed \$450,000.00.

3) Contract No. 3586 with The Mannik & Smith Group, Inc. in the amount not-to-exceed \$450,000.00.

g) R2023-0215: A Resolution making an award on RQ12731 with R. L. Hill Management, Inc., in the amount not-to-exceed \$2,155,521.00 for construction of a multi-purpose room addition at the Cuyahoga County Animal Shelter; authorizing the County Executive to execute Contract No. 3588 and all other documents consistent with said award and this Resolution; and declaring the necessity that this Resolution become immediately effective. [See page 111]

6. MISCELLANEOUS BUSINESS

7. ADJOURNMENT

**Complimentary parking for the public is available in the attached garage at 900 Prospect. A skywalk extends from the garage to provide additional entry to the Council Chambers from the 5th floor parking level of the garage. Please see the Clerk to obtain a complimentary parking pass.*

***Council Chambers is equipped with a hearing assistance system. If needed, please see the Clerk to obtain a receiver.*



MINUTES

CUYAHOGA COUNTY PUBLIC WORKS, PROCUREMENT & CONTRACTING
COMMITTEE MEETING
WEDNESDAY, JULY 12, 2023
CUYAHOGA COUNTY ADMINISTRATIVE HEADQUARTERS
C. ELLEN CONNALLY COUNCIL CHAMBERS – 4TH FLOOR
10:00 AM

1. CALL TO ORDER

Chairman Tuma called the meeting to order at 10:03 a.m.

2. ROLL CALL

Mr. Tuma asked Deputy Clerk Carter to call the roll. Committee members Tuma, Miller, Conwell and Turner were in attendance and a quorum was determined. Committee member Sweeney was absent from the meeting.

3. PUBLIC COMMENT

There were no public comments given.

4. APPROVAL OF MINUTES FROM THE JUNE 28, 2023 MEETING

A motion was made by Ms. Turner, seconded by Mr. Miller and approved by unanimous vote to approve the minutes from the June 28, 2023 meeting.

5. MATTERS REFERRED TO COMMITTEE

- a) R2023-0195: A Resolution declaring that public convenience and welfare requires the resurfacing of West 140th Street from Puritas Avenue to Lakewood Heights Boulevard in the City of Cleveland at a total estimated project cost of \$5,872,981.00 and finding that special assessments will neither be levied nor collected to pay for any part of the County's costs of said improvement; authorizing the County

Executive to enter into an agreement of cooperation with City of Cleveland in connection with said project; and declaring the necessity that this Resolution become immediately effective.

Ms. Nichole English, Planning and Program Administrator, addressed the Committee regarding Resolution No. R2023-0195. Discussion ensued.

Committee members asked questions of Ms. English pertaining to the item, which she answered accordingly.

On a motion by Mr. Tuma with a second by Ms. Conwell, Resolution No. R2023-0195 was considered and approved by unanimous vote to be referred to the full Council agenda for second reading.

- b) R2023-0196: A Resolution declaring that public convenience and welfare requires the replacement of Schaaf Road Bridge No. 02.89 over West Creek in the City of Independence at a total estimated project cost of \$2,405,600.00 and finding that special assessments will neither be levied nor collected to pay for any part of the County's costs of said improvement; authorizing the County Executive to enter into an agreement of cooperation with City of Independence in connection with said project; and declaring the necessity that this Resolution become immediately effective.

Ms. English addressed the Committee regarding Resolution No. R2023-0196. Discussion ensued.

Committee members asked questions of Ms. English pertaining to the item, which she answered accordingly.

On a motion by Mr. Tuma with a second by Ms. Turner, Resolution No. R2023-0196 was considered and approved by unanimous vote to be referred to the full Council agenda for second reading.

- c) R2023-0197: A Resolution declaring that public convenience and welfare requires the rehabilitation of North Marginal Road Connector from East 9th Street to East 55th Street in the City of Cleveland at a total estimated project cost of \$12,084,048.00 and finding that special assessments will neither be levied nor collected to pay for any part of the County's costs of said improvement; authorizing the County Executive to enter into an agreement of cooperation with City of Cleveland in connection with said project; and declaring the necessity that this Resolution become immediately effective.

Ms. English and Mr. Trevor Hunt, Senior Project Manager, addressed the Committee regarding Resolution No. R2023-0197. Discussion ensued.

Committee members asked questions of Ms. English and Mr. Hunt pertaining to the item, which they answered accordingly.

On a motion by Mr. Tuma with a second by Ms. Conwell, Resolution No. R2023-0197 was considered and approved by unanimous vote to be referred to the full Council agenda with a recommendation for passage under second reading suspension of the rules.

Committee members Turner and Conwell requested to have their names added as co-sponsors to the legislation.

- d) R2023-0198: A Resolution making an award on RQ12514 to The Ruhlin Company in the amount not-to-exceed \$4,425,425.50 for replacement of West 130th Street Bridge No. 02.26 over the East Branch of the Rocky River in the Cities of North Royalton and Strongsville; authorizing the County Executive to execute Contract No. 3567 and all other documents consistent with said award and this Resolution; authorizing the County Engineer, on behalf of the County Executive, to make an allocation from County Motor Vehicle \$7.50 License Tax Funds in the amount \$2,814,570.43 to fund said contract; and declaring the necessity that this Resolution become immediately effective.

Ms. English addressed the Committee regarding Resolution No. R2023-0198. Discussion ensued.

Committee members asked questions of Ms. English pertaining to the item, which she answered accordingly.

On a motion by Mr. Tuma with a second by Ms. Turner, Resolution No. R2023-0198 was considered and approved by unanimous vote to be referred to the full Council agenda with a recommendation for passage under second reading suspension of the rules.

6. MISCELLANEOUS BUSINESS

There was no miscellaneous business.

7. ADJOURNMENT

With no further business to discuss and on a motion by Mr. Tuma with a second by Mr. Miller, the meeting was adjourned at 10:31 a.m., without objection.

County Council of Cuyahoga County, Ohio

Resolution No. R2023-0209

Sponsored by: County Executive Ronayne/Department of Public Works	A Resolution declaring that public convenience and welfare requires the resurfacing of Snow Road from Ridge Road to State Road in the City of Parma and finding that special assessments will neither be levied nor collected to pay for any part of the County's costs of said improvement; authorizing the County Executive to enter into an agreement of cooperation with City of Parma in connection with said project; and declaring the necessity that this Resolution become immediately effective.
--	---

WHEREAS, the County Executive/Department of Public Works recommends that public convenience and welfare requires the resurfacing of Snow Road from Ridge Road to State Road in the City of Parma; and

WHEREAS, the anticipated start date is summer of 2025; and

WHEREAS, that special assessments will neither be levied nor collected to pay for any part of the County's costs of said improvement; and

WHEREAS, the primary goal is to properly maintain the County's infrastructure for which the County is responsible; and

WHEREAS, the project is located in Cuyahoga County Council District 4; and

WHEREAS, the estimated project cost is \$2,429,196.00; and

WHEREAS, this project will be funded 80% (\$1,943,356.80) Federal, 10% (\$242,919.60) Cleveland/Cleveland Metroparks and 10% (\$242,919.60) County Road and Bridge Fund; and

WHEREAS, it is necessary that this Resolution become immediately effective in order that critical services provided by Cuyahoga County can continue and to provide for the usual, daily operation of a County entity.

NOW, THEREFORE, BE IT RESOLVED BY THE COUNTY COUNCIL OF CUYAHOGA COUNTY, OHIO:

SECTION 1. That the Cuyahoga County Council hereby declares that public convenience and welfare requires the resurfacing of Snow Road from Ridge Road to State Road in the City of Parma.

SECTION 2. That special assessments will neither be levied nor collected to pay for any part of the County's costs of said improvements.

SECTION 3. That the County Executive is hereby authorized to enter into and execute any and all necessary agreements of cooperation and any other documents in connection with this project.

SECTION 4. It is necessary that this Resolution become immediately effective for the usual daily operation of the County; the preservation of public peace, health or safety in the County; and any additional reasons set forth in the preamble. Provided that this Resolution receives the affirmative vote of at least eight members of Council, it shall take effect and be in force immediately upon the earliest occurrence of any of the following: (1) its approval by the County Executive through signature, (2) the expiration of the time during which it may be disapproved by the County Executive under Section 3.10(6) of the Cuyahoga County Charter, or (3) its passage by at least eight members of Council after disapproval pursuant to Section 3.10(7) of the Cuyahoga County Charter. Otherwise, it shall take effect and be in force from and after the earliest period allowed by law.

SECTION 5. It is found and determined that all formal actions of this Council relating to the adoption of this Resolution were adopted in an open meeting of the Council, and that all deliberations of this Council and of any of its committees that resulted in such formal action were in meetings open to the public, in compliance with all legal requirements, including Section 121.22 of the Ohio Revised Code.

On a motion by _____, seconded by _____, the foregoing Resolution was duly adopted.

Yeas:

Nays:

County Council President

Date

County Executive

Date

Clerk of Council

Date

First Reading/Referred to Committee: July 18, 2023
Committee(s) Assigned: Public Works, Procurement & Contracting

Journal _____
_____, 20__

Public Works Requests Approval of the Public Convenience and Welfare for the Resurfacing of Snow Road, in the City of Parma

Scope of Work Summary

The Public Works Department is requesting that Council find:

- That public convenience and welfare requires the approval of the resurfacing of Snow Road from Ridge Road to State Road, in the City of Parma.
- That special assessments are not to be levied and collected to pay part of the County's costs of these improvements.
- Authorize the County Executive to enter into and execute the necessary agreements of cooperation with the appropriate municipality. The anticipated cost of this project is \$2,429,196. This project is part of the NOACA TIP 2021-2024 and the County is requesting to be the project sponsor. The anticipated start date is the Spring of 2025 and it is anticipated to be completed in the Fall of 2025.

The primary goal of this request is to begin the process of Council review and approval of this project. The primary goal of the project itself is the approval of Convenience and Welfare.

Procurement – N/A

Contractor and Project Information – N/A

Council District 4

Project Status and Planning

The project is new to the County.

Funding

The project is to be funded with funded \$1,943,357 Federal (80%), \$242,920 County Road and Bridge (10%) and \$242,919 Parma (10%). The total cost of the project is \$2,429,196. By Invoice



CUYAHOGA COUNTY DEPARTMENT of PUBLIC WORKS

Project Fact Sheet – Snow Road, in Parma

Project Type	Roadway Resurfacing
Project Limits	Ridge Road to State Road
Project Length	1.30 miles
Average Daily Traffic	16,487 vehicles per day
Pavement Condition Rating	72 (Fair)
Previously Resurfaced	2009
Council District	4
Project Cost	\$2,429,196
Proposed Funding	80% Federal (\$1,943,357), 10% County (\$242,920), 10% Parma (\$242,919)
Project Design	Parma
Construction Admin	Cuyahoga County

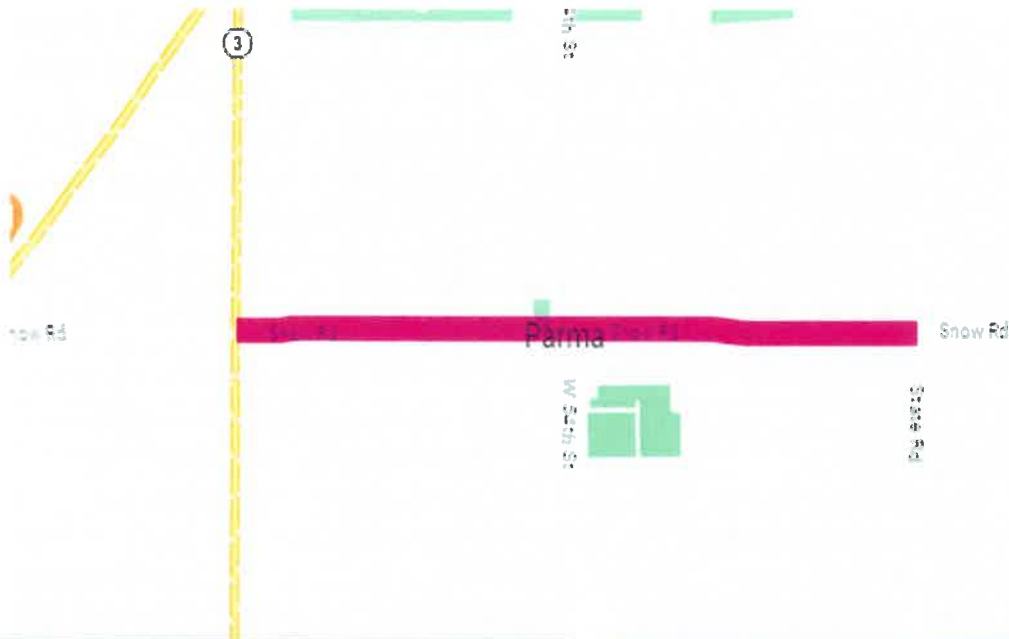

County Council of Cuyahoga County, Ohio

Resolution No. R2023-0210

Sponsored by: County Executive Ronayne/Department of Public Works/Division of County Engineer	A Resolution approving Right-of-Way Exhibits as set forth in Plat No. M-5052 for rehabilitation of North Marginal Road Connector from East 9 th Street to East 55 th Street in the City of Cleveland; authorizing the County Executive through the Department of Public Works to acquire said necessary Right-of-Way; and declaring the necessity that this Resolution become immediately effective.
--	---

WHEREAS, the County Executive/Department of Public Works/Division of County Engineer recommends approving Right-of-Way Exhibits as set forth in Plat No. M-5052 for rehabilitation of North Marginal Road Connector from East 9th Street to East 55th Street in the City of Cleveland; and

WHEREAS, the primary goal of this project is to obtain Council’s review and approval of the right-of-way plans and approval of the required acquisition needed for rehabilitation of North Marginal Road Connector from East 9th Street to East 55th Street in the City of Cleveland; and

WHEREAS, the project is located in Council District 7; and

WHEREAS, the anticipated right-of-way acquisition cost is \$150,000.00 which will be funded 100% by County Road and Bridge Funds; and

WHEREAS, it is necessary that this Resolution become immediately effective in order that critical services provided by Cuyahoga County can continue and to provide for the usual, daily operation of a County entity.

NOW, THEREFORE, BE IT RESOLVED BY THE COUNTY COUNCIL OF CUYAHOGA COUNTY, OHIO:

SECTION 1. That the Cuyahoga County Council hereby approves Right-of-Way Exhibits as set forth in Plat No. M-5052 for rehabilitation of North Marginal Road Connector from East 9th Street to East 55th Street in the City of Cleveland.

SECTION 2. That the County Executive through the Department of Public Works is hereby authorized to acquire the Right-of-Way necessary for said improvement.

SECTION 3. That all proceedings relative to Right-of-Way as set forth in Plat No. M-5052 are hereby ordered copied into the Road Record of the County by the Department of Public Works and copied into all other proper records of the County by the Fiscal Officer as required by law.

SECTION 4. It is necessary that this Resolution become immediately effective for the usual daily operation of the County; the preservation of public peace, health or safety in the County; and any additional reasons set forth in the preamble. Provided that this Resolution receives the affirmative vote of at least eight members of Council, it shall take effect and be in force immediately upon the earliest occurrence of any of the following: (1) its approval by the County Executive through signature, (2) the expiration of the time during which it may be disapproved by the County Executive under Section 3.10(6) of the Cuyahoga County Charter, or (3) its passage by at least eight members of Council after disapproval pursuant to Section 3.10(7) of the Cuyahoga County Charter. Otherwise, it shall take effect and be in force from and after the earliest period allowed by law.

SECTION 5. It is found and determined that all formal actions of this Council relating to the adoption of this Resolution were adopted in an open meeting of the Council, and that all deliberations of this Council and of any of its committees that resulted in such formal action were in meetings open to the public, in compliance with all legal requirements, including Section 121.22 of the Ohio Revised Code.

On a motion by _____, seconded by _____, the foregoing Resolution was duly adopted.

Yeas:

Nays:

County Council President

Date

County Executive

Date

Clerk of Council

Date

First Reading/Referred to Committee: July 18, 2023
Committee(s) Assigned: Public Works, Procurement & Contracting

Journal _____
_____, 20__

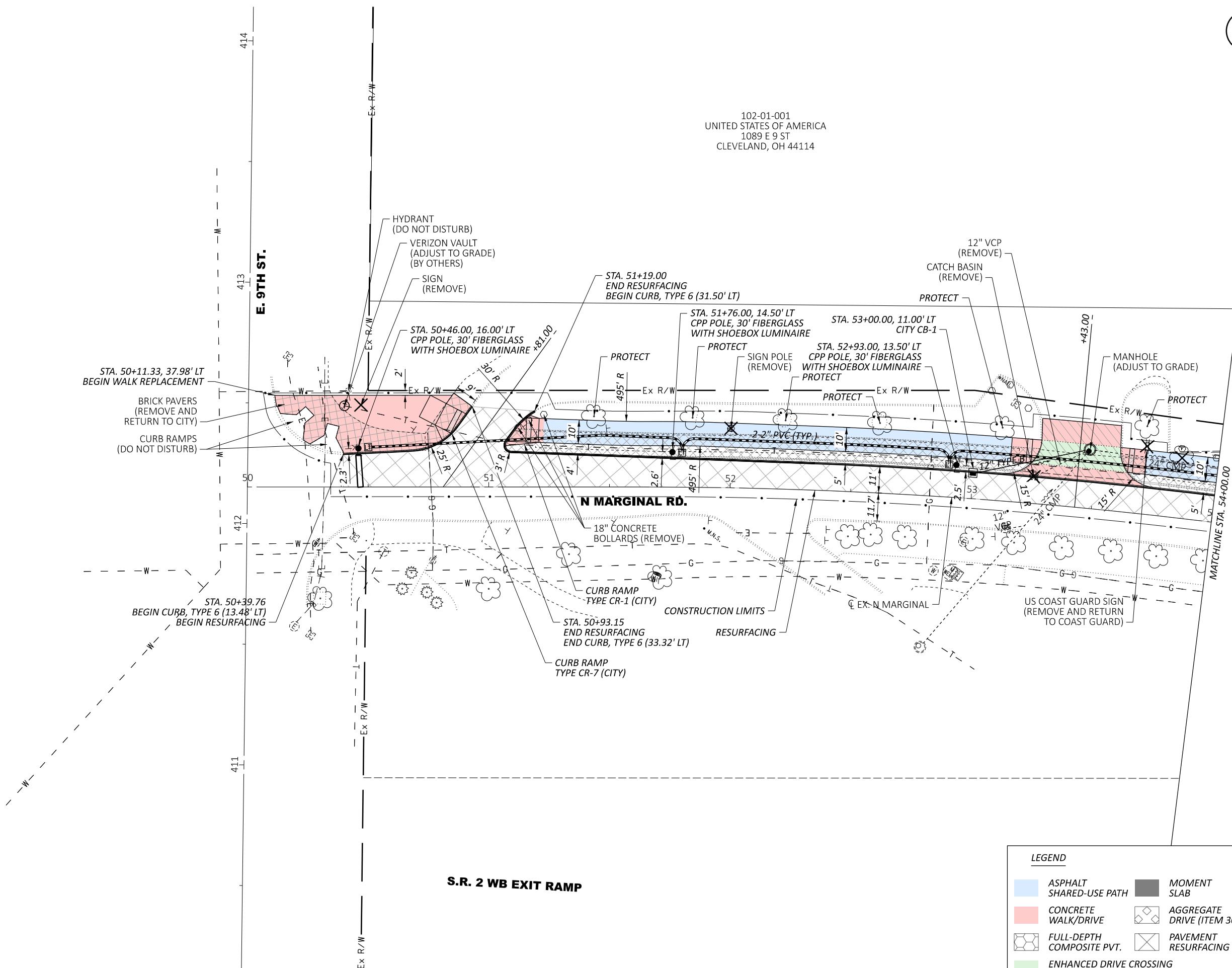

102-01-001
 UNITED STATES OF AMERICA
 1089 E 9 ST
 CLEVELAND, OH 44114

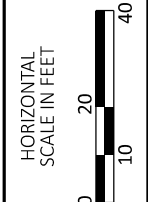

PLAN - N MARGINAL RD.
 STA. 50+00.00 TO STA. 54+00.00

LEGEND			
	ASPHALT SHARED-USE PATH		MOMENT SLAB
	CONCRETE WALK/DRIVE		AGGREGATE DRIVE (ITEM 304)
	FULL-DEPTH COMPOSITE PVT.		PAVEMENT RESURFACING
	ENHANCED DRIVE CROSSING INTEGRALLY COLORED CONCRETE		EX. TREE (DO NOT DISTURB)
			EX. TREE (REMOVE)
			PR. TREE
			PAVEMENT REMOVED
			WALK REMOVED

S.R. 2 WB EXIT RAMP

DESIGN AGENCY	Michael Baker INTERNATIONAL
DESIGNER	---
REVIEWER	---
PROJECT ID	118968
SHEET	26
TOTAL	138

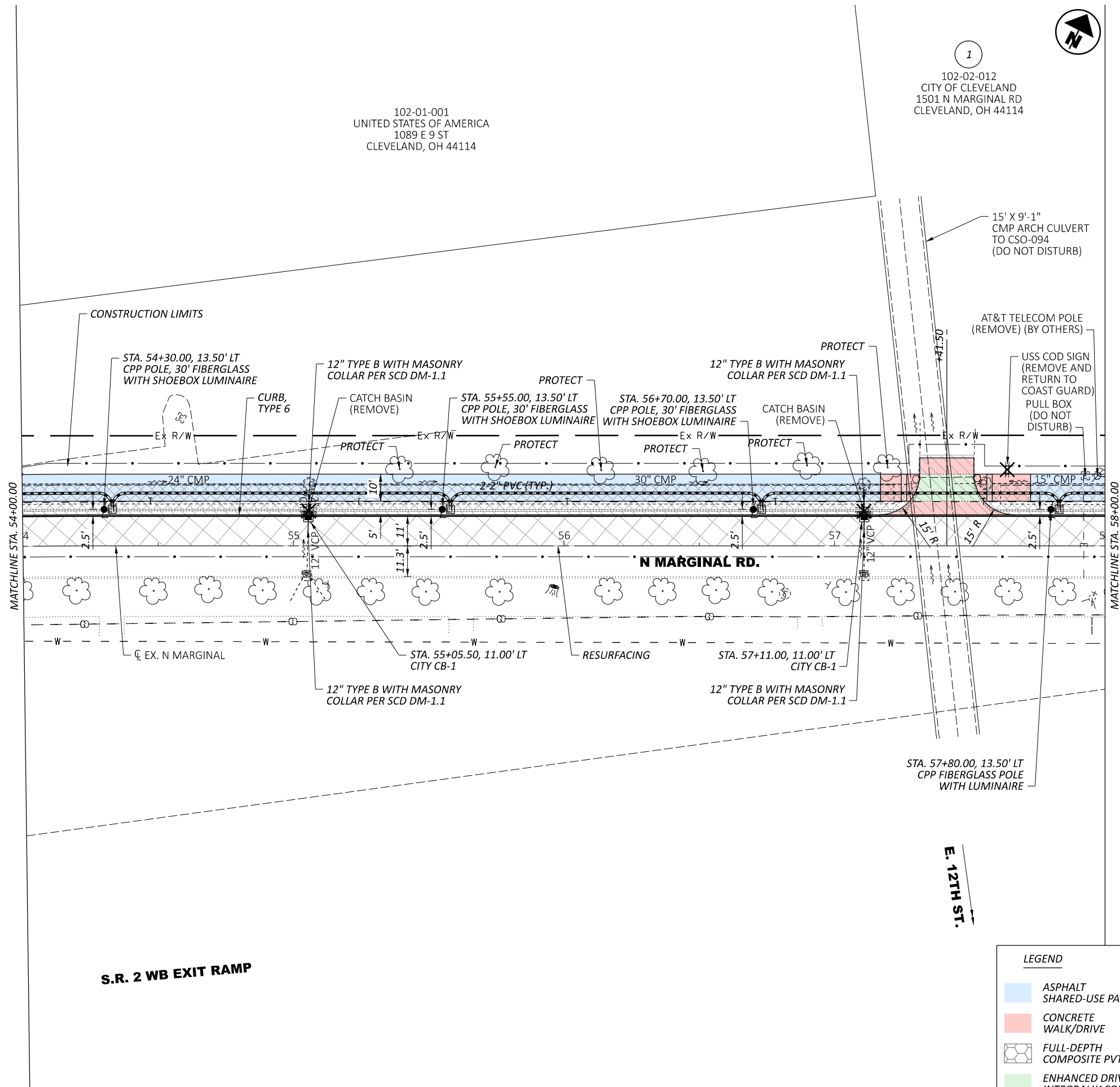

102-01-001
 UNITED STATES OF AMERICA
 1089 E 9 ST
 CLEVELAND, OH 44114

1
 102-02-012
 CITY OF CLEVELAND
 1501 N MARGINAL RD
 CLEVELAND, OH 44114

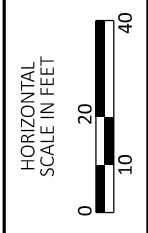

PLAN - N MARGINAL RD.
 STA. 54+00.00 TO STA. 58+00.00

S.R. 2 WB EXIT RAMP

LEGEND			
	ASPHALT SHARED-USE PATH		MOMENT SLAB
	CONCRETE WALK/DRIVE		AGGREGATE DRIVE (ITEM 304)
	ENHANCED DRIVE CROSSING INTEGRALLY COLORED CONCRETE		PAVEMENT RESURFACING
	PAVEMENT REMOVED		EX. TREE (DO NOT DISTURB)
	WALK REMOVED		EX. TREE (REMOVE)
	PR. TREE		

DESIGN AGENCY	Michael Baker INTERNATIONAL
DESIGNER	---
REVIEWER	---
PROJECT ID	118968
SHEET	27
TOTAL	138

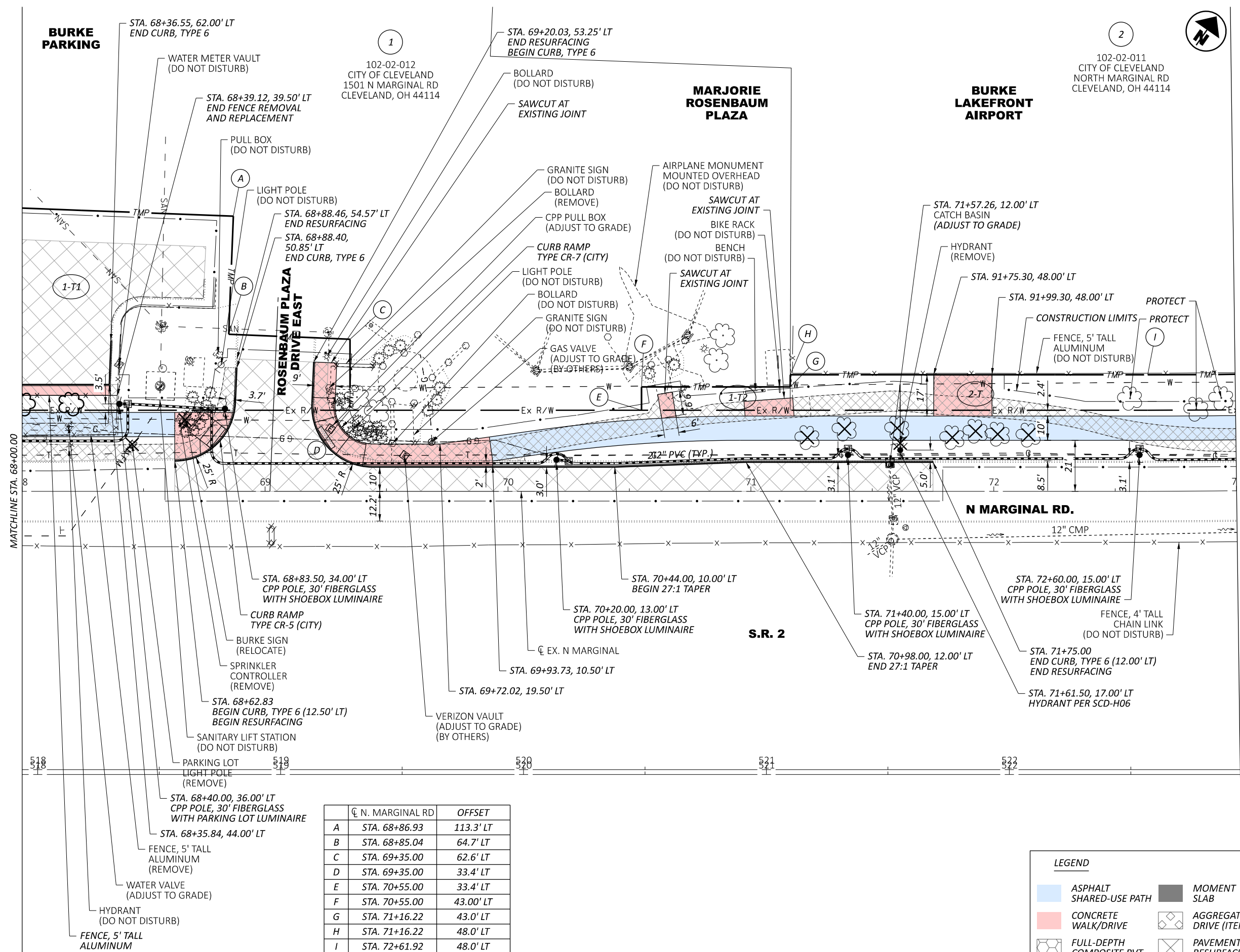

	☐ N. MARGINAL RD	OFFSET
A	STA. 68+86.93	113.3' LT
B	STA. 68+85.04	64.7' LT
C	STA. 69+35.00	62.6' LT
D	STA. 69+35.00	33.4' LT
E	STA. 70+55.00	33.4' LT
F	STA. 70+55.00	43.00' LT
G	STA. 71+16.22	43.0' LT
H	STA. 71+16.22	48.0' LT
I	STA. 72+61.92	48.0' LT

LEGEND

	ASPHALT SHARED-USE PATH		MOMENT SLAB		PAVEMENT REMOVED
	CONCRETE WALK/DRIVE		AGGREGATE DRIVE (ITEM 304)		WALK REMOVED
	FULL-DEPTH COMPOSITE PVT.		PAVEMENT RESURFACING		EX. TREE (DO NOT DISTURB)
	ENHANCED DRIVE CROSSING INTEGRALLY COLORED CONCRETE				EX. TREE (REMOVE)
					PR. TREE

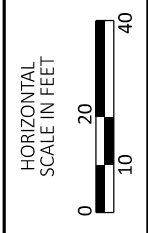

PLAN - N MARGINAL RD.
 STA. 68+00.00 TO STA. 73+00.00

DESIGN AGENCY	Michael Baker International
DESIGNER	---
REVIEWER	---
PROJECT ID	118968
SHEET	30
TOTAL	138

102-02-011
 CITY OF CLEVELAND
 NORTH MARGINAL RD
 CLEVELAND, OH 44114

**SIGNATURE
 FLIGHT
 SUPPORT**

102-02-007
 REMMERT-WERNER INC LEASE
 1601 NORTH MARGINAL RD
 CLEVELAND, OH 44114

**BURKE
 LAKEFRONT
 AIRPORT**

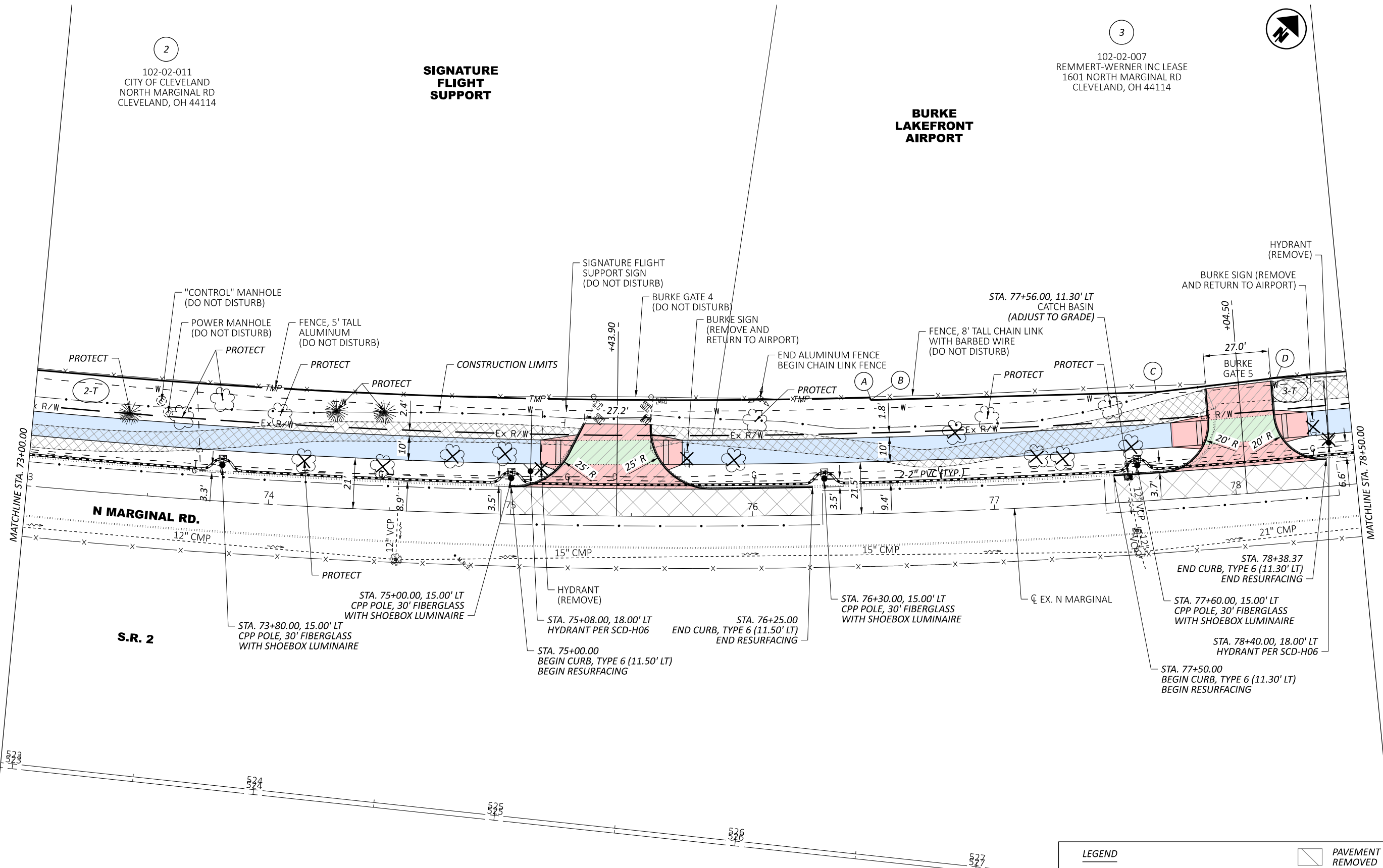

	CL N. MARGINAL RD	OFFSET
A	STA. 76+50.00	48.0' LT
B	STA. 76+50.00	47.0' LT
C	STA. 77+69.88	44.6' LT
D	STA. 78+20.64	46.6' LT

LEGEND

	ASPHALT SHARED-USE PATH		MOMENT SLAB		PAVEMENT REMOVED
	CONCRETE WALK/DRIVE		AGGREGATE DRIVE (ITEM 304)		WALK REMOVED
	FULL-DEPTH COMPOSITE PVT.		PAVEMENT RESURFACING		EX. TREE (DO NOT DISTURB)
	ENHANCED DRIVE CROSSING INTEGRALLY COLORED CONCRETE				EX. TREE (REMOVE)
					PR. TREE

PLAN - N MARGINAL RD.
 STA. 73+00.00 TO STA. 78+50.00

DESIGN AGENCY	Michael Baker INTERNATIONAL
DESIGNER	---
REVIEWER	---
PROJECT ID	118968
SHEET TOTAL	31 138

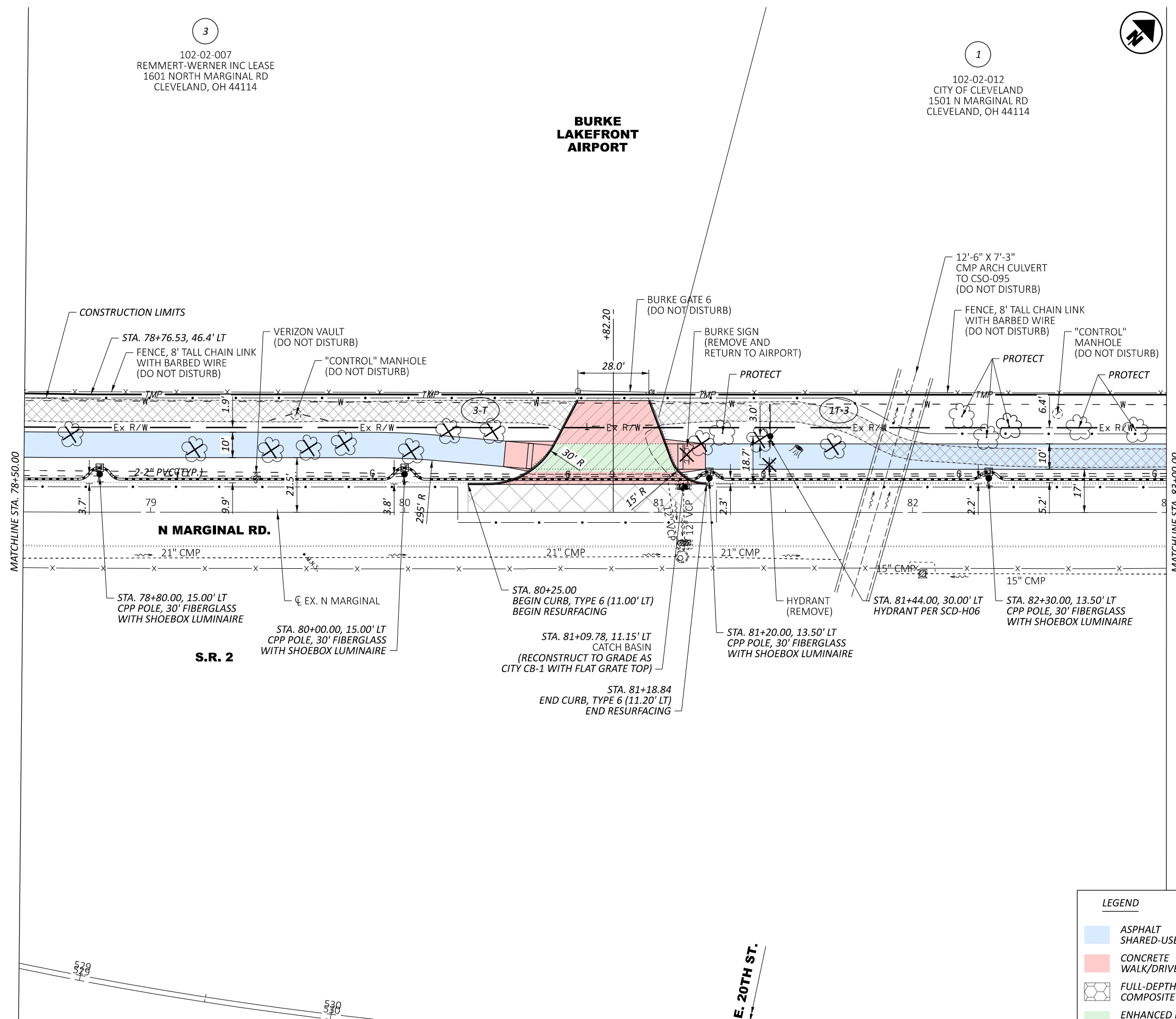

3
 102-02-007
 REMMERT-WERNER INC LEASE
 1601 NORTH MARGINAL RD
 CLEVELAND, OH 44114

1
 102-02-012
 CITY OF CLEVELAND
 1501 N MARGINAL RD
 CLEVELAND, OH 44114

**BURKE
 LAKEFRONT
 AIRPORT**

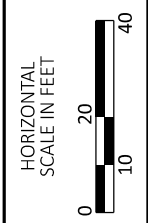

**PLAN - N MARGINAL RD.
 STA. 78+50.00 TO STA. 83+00.00**

LEGEND			
	ASPHALT SHARED-USE PATH		MOMENT SLAB
	CONCRETE WALK/DRIVE		AGGREGATE DRIVE (ITEM 304)
	FULL-DEPTH COMPOSITE PVT.		PAVEMENT RESURFACING
	ENHANCED DRIVE CROSSING INTEGRALLY COLORED CONCRETE		PAVEMENT REMOVED
	EX. TREE (DO NOT DISTURB)		EX. TREE (REMOVE)
	PR. TREE		WALK REMOVED

DESIGN AGENCY	Michael Baker INTERNATIONAL
DESIGNER	---
REVIEWER	---
PROJECT ID	118968
SHEET	32
TOTAL	138

1
 102-02-012
 CITY OF CLEVELAND
 1501 N MARGINAL RD
 CLEVELAND, OH 44114

4
 102-03-003
 CITY OF CLEVELAND
 1501 NORTH MARGINAL RD
 CLEVELAND, OH 44114

BURKE LAKEFRONT AIRPORT

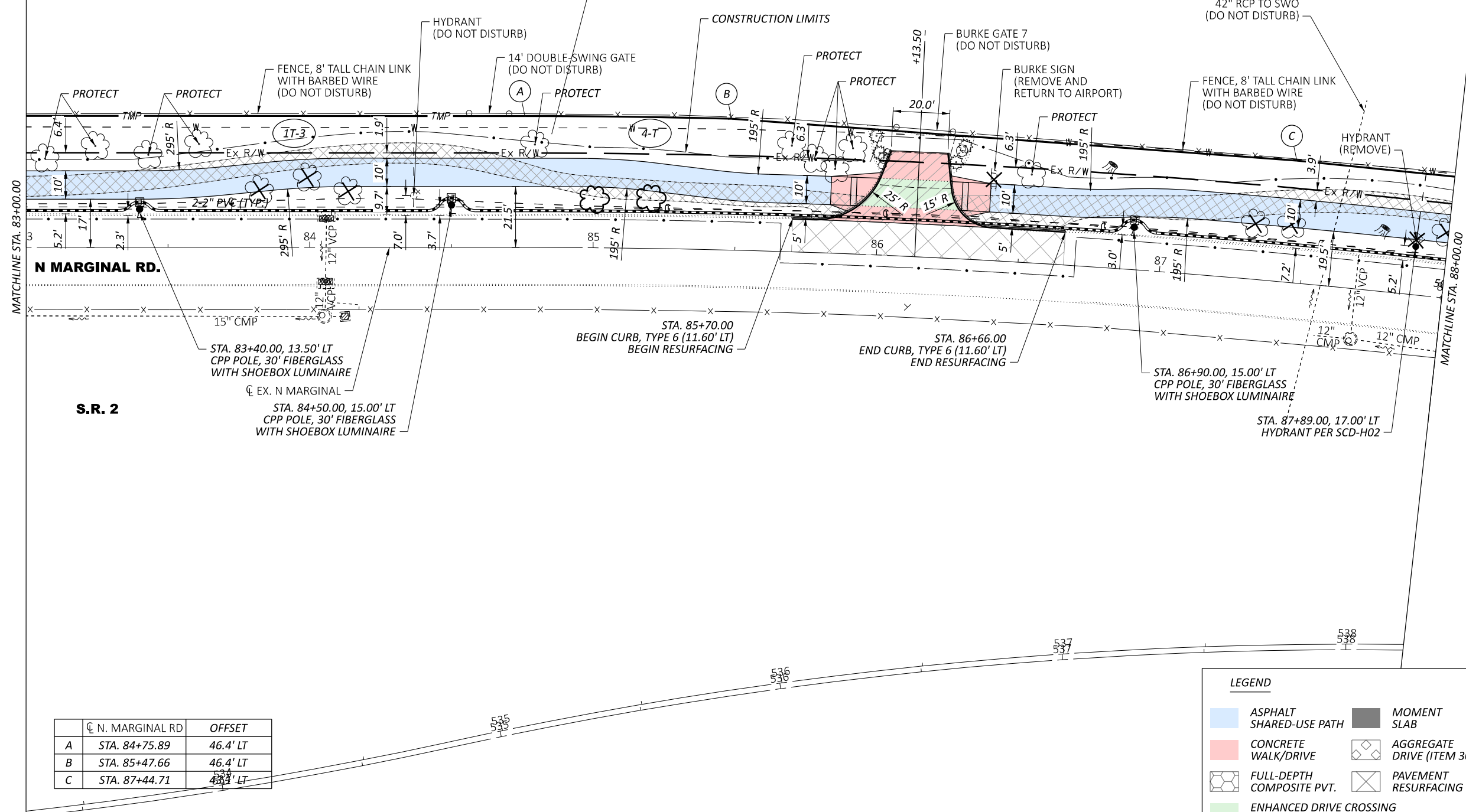

	☐ N. MARGINAL RD	OFFSET
A	STA. 84+75.89	46.4' LT
B	STA. 85+47.66	46.4' LT
C	STA. 87+44.71	43.4' LT

LEGEND

	ASPHALT SHARED-USE PATH		MOMENT SLAB		PAVEMENT REMOVED
	CONCRETE WALK/DRIVE		AGGREGATE DRIVE (ITEM 304)		WALK REMOVED
	FULL-DEPTH COMPOSITE PVT.		PAVEMENT RESURFACING		EX. TREE (DO NOT DISTURB)
	ENHANCED DRIVE CROSSING INTEGRALLY COLORED CONCRETE				EX. TREE (REMOVE)
					PR. TREE

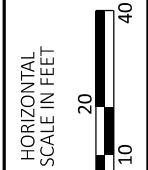

PLAN - N MARGINAL RD.
 STA. 83+00.00 TO STA. 88+00.00

DESIGN AGENCY	Michael Baker INTERNATIONAL
DESIGNER	---
REVIEWER	---
PROJECT ID	118968
SHEET	33
TOTAL	138

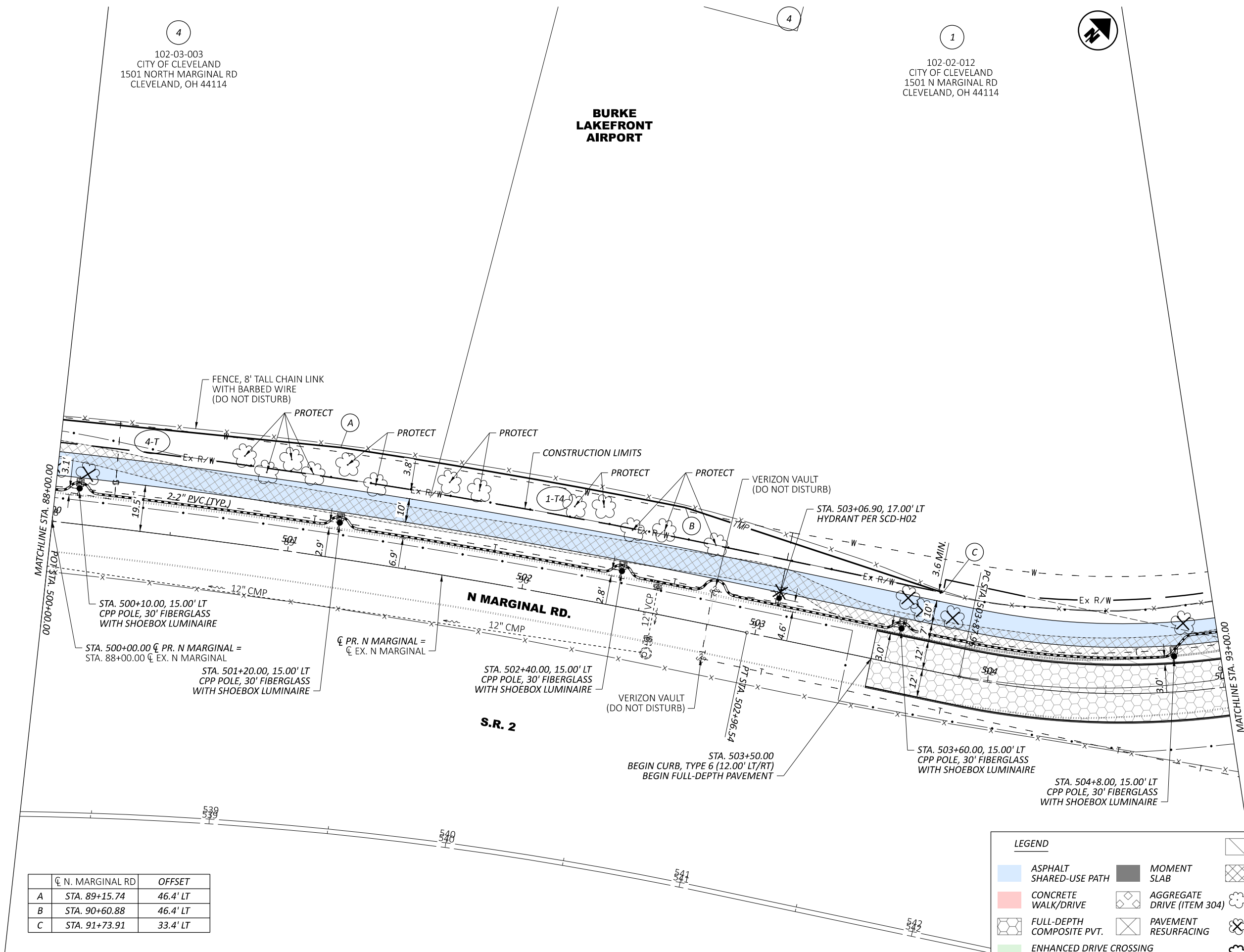

	☐ N. MARGINAL RD	OFFSET
A	STA. 89+15.74	46.4' LT
B	STA. 90+60.88	46.4' LT
C	STA. 91+73.91	33.4' LT

LEGEND		
	ASPHALT SHARED-USE PATH	
	CONCRETE WALK/DRIVE	
	FULL-DEPTH COMPOSITE PVT.	
	ENHANCED DRIVE CROSSING INTEGRALLY COLORED CONCRETE	
	MOMENT SLAB	
	AGGREGATE DRIVE (ITEM 304)	
	PAVEMENT RESURFACING	
	PAVEMENT REMOVED	
	WALK REMOVED	
	EX. TREE (DO NOT DISTURB)	
	EX. TREE (REMOVE)	
	PR. TREE	

102-03-003
 CITY OF CLEVELAND
 1501 NORTH MARGINAL RD
 CLEVELAND, OH 44114

102-02-012
 CITY OF CLEVELAND
 1501 N MARGINAL RD
 CLEVELAND, OH 44114

**BURKE
 LAKEFRONT
 AIRPORT**

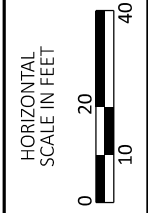

PLAN - N MARGINAL RD.
 STA. 88+00.00 TO STA. 93+00.00

DESIGN AGENCY	Michael Baker INTERNATIONAL
DESIGNER	---
REVIEWER	---
PROJECT ID	118968
SHEET	34
TOTAL	138

1
 102-02-012
 CITY OF CLEVELAND
 1501 N MARGINAL RD
 CLEVELAND, OH 44114

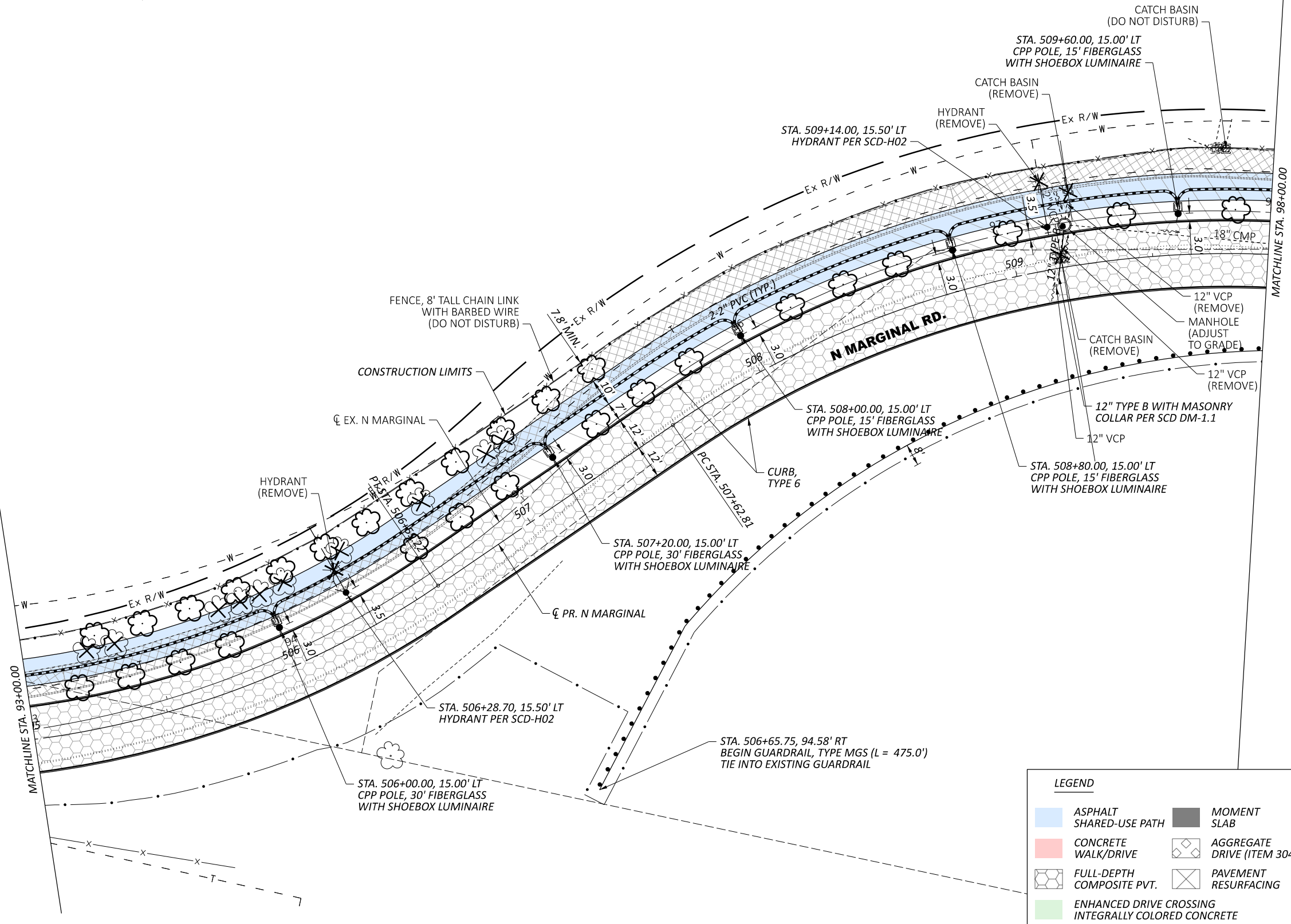

PLAN - N MARGINAL RD.
 STA. 93+00.00 TO STA. 98+00.00

LEGEND					
	ASPHALT SHARED-USE PATH		MOMENT SLAB		PAVEMENT REMOVED
	CONCRETE WALK/DRIVE		AGGREGATE DRIVE (ITEM 304)		EX. TREE (DO NOT DISTURB)
	FULL-DEPTH COMPOSITE PVT.		PAVEMENT RESURFACING		EX. TREE (REMOVE)
	ENHANCED DRIVE CROSSING INTEGRALLY COLORED CONCRETE				PR. TREE

DESIGN AGENCY	Michael Baker INTERNATIONAL
DESIGNER	---
REVIEWER	---
PROJECT ID	118968
SHEET	35
TOTAL	138

1
 102-02-012
 CITY OF CLEVELAND
 1501 N MARGINAL RD
 CLEVELAND, OH 44114

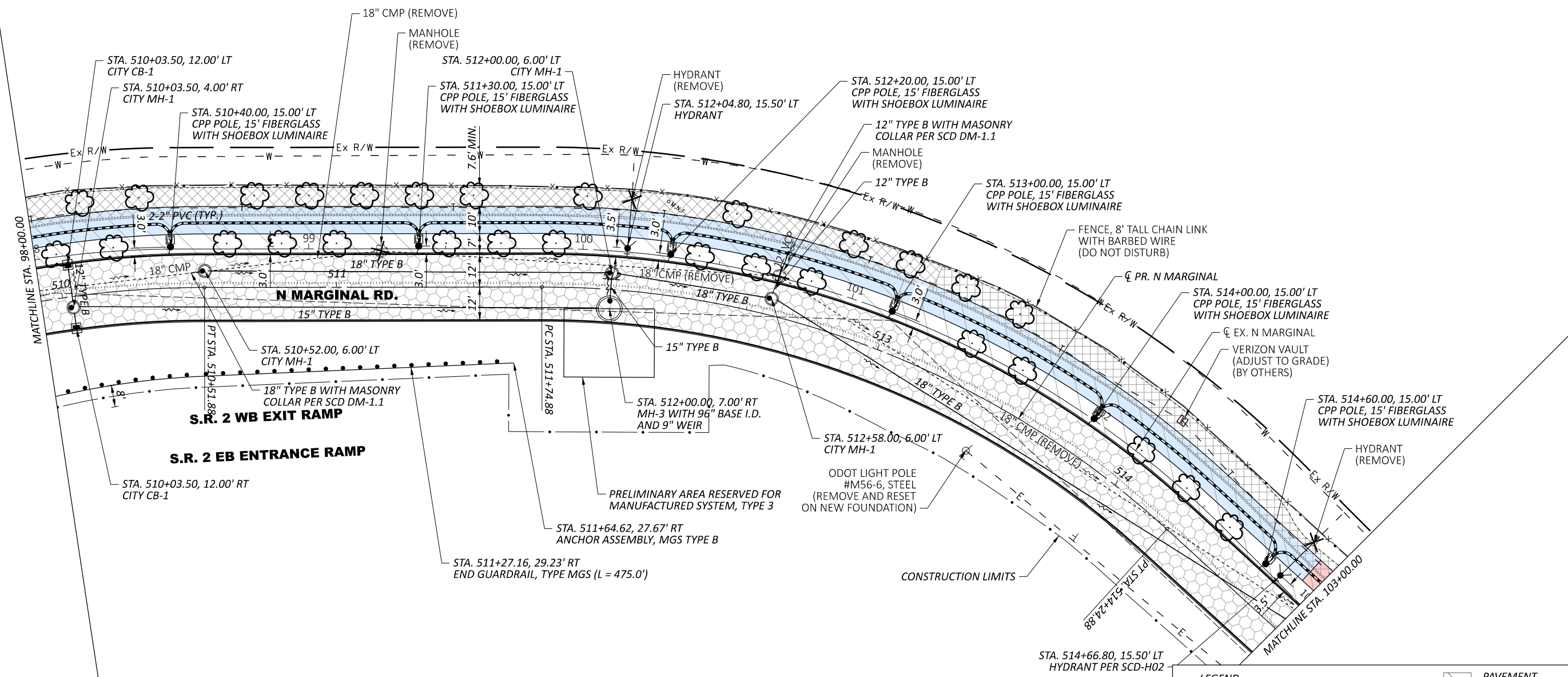
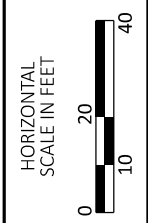

PLAN - N MARGINAL RD.
 STA. 98+00.00 TO STA. 103+00.00

LEGEND			
	ASPHALT SHARED-USE PATH		MOMENT SLAB
	CONCRETE WALK/DRIVE		AGGREGATE DRIVE (ITEM 304)
	FULL-DEPTH COMPOSITE PVT.		PAVEMENT RESURFACING
	ENHANCED DRIVE CROSSING INTEGRALLY COLORED CONCRETE		EX. TREE (DO NOT DISTURB)
			EX. TREE (REMOVE)
			PR. TREE
			PAVEMENT REMOVED
			WALK REMOVED

DESIGN AGENCY	Michael Baker INTERNATIONAL
DESIGNER	---
REVIEWER	---
PROJECT ID	118968
SHEET	36
TOTAL	138

1
 102-02-012
 CITY OF CLEVELAND
 1501 N MARGINAL RD
 CLEVELAND, OH 44114

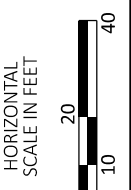

BURKE LAKEFRONT AIRPORT

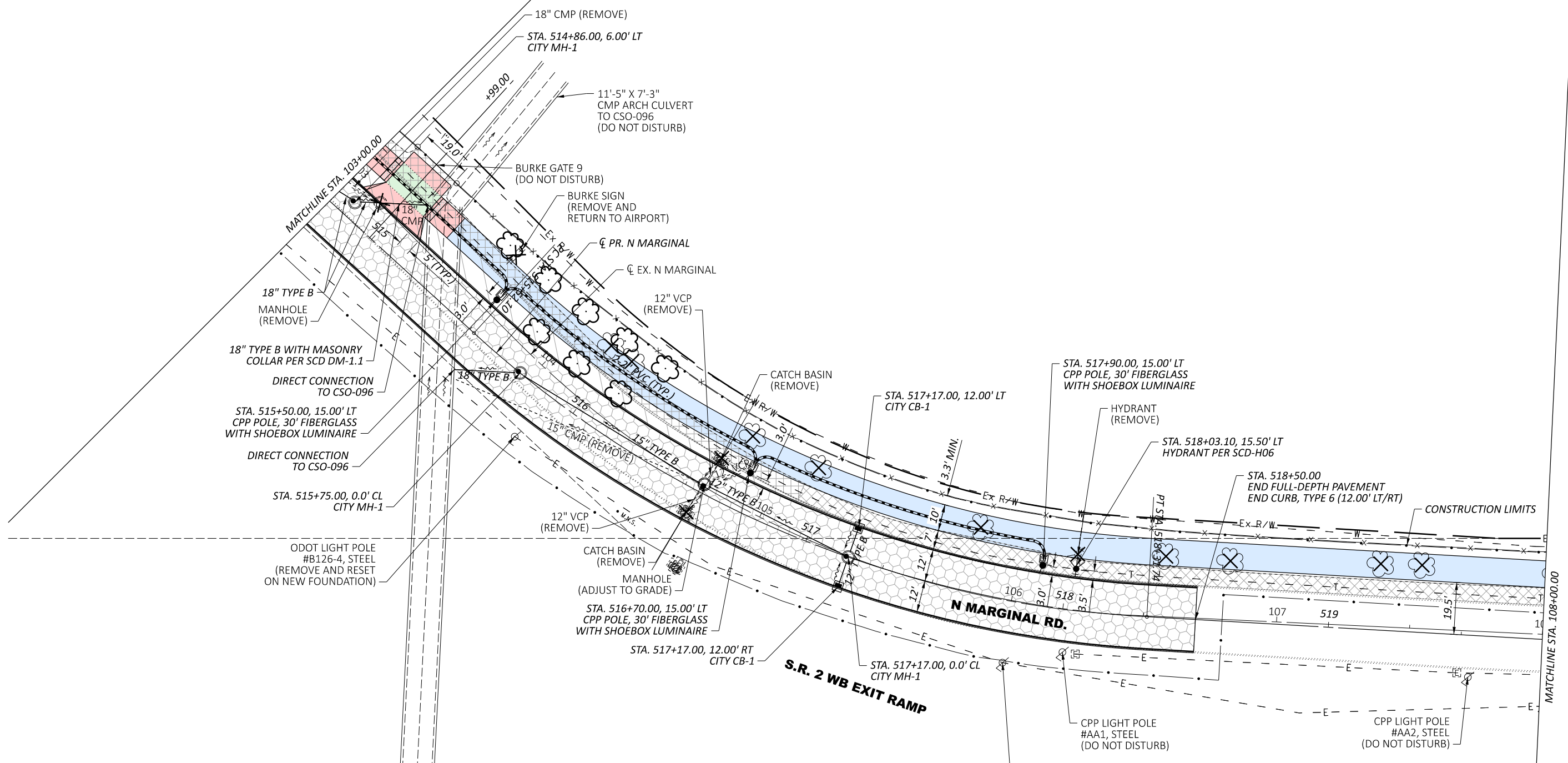

PLAN - N MARGINAL RD.
 STA. 103+00.00 TO STA. 108+00.00

E. 26TH ST.

S.R. 2

LEGEND	
	ASPHALT SHARED-USE PATH
	CONCRETE WALK/DRIVE
	FULL-DEPTH COMPOSITE PVT.
	ENHANCED DRIVE CROSSING INTEGRALLY COLORED CONCRETE
	MOMENT SLAB
	AGGREGATE DRIVE (ITEM 304)
	PAVEMENT RESURFACING
	PAVEMENT REMOVED
	WALK REMOVED
	EX. TREE (DO NOT DISTURB)
	EX. TREE (REMOVE)
	PR. TREE

DESIGN AGENCY	Michael Baker INTERNATIONAL
DESIGNER	---
REVIEWER	---
PROJECT ID	118968
SHEET	37
TOTAL	138

1
 102-02-012
 CITY OF CLEVELAND
 1501 N MARGINAL RD
 CLEVELAND, OH 44114

**BURKE
 LAKEFRONT
 AIRPORT**

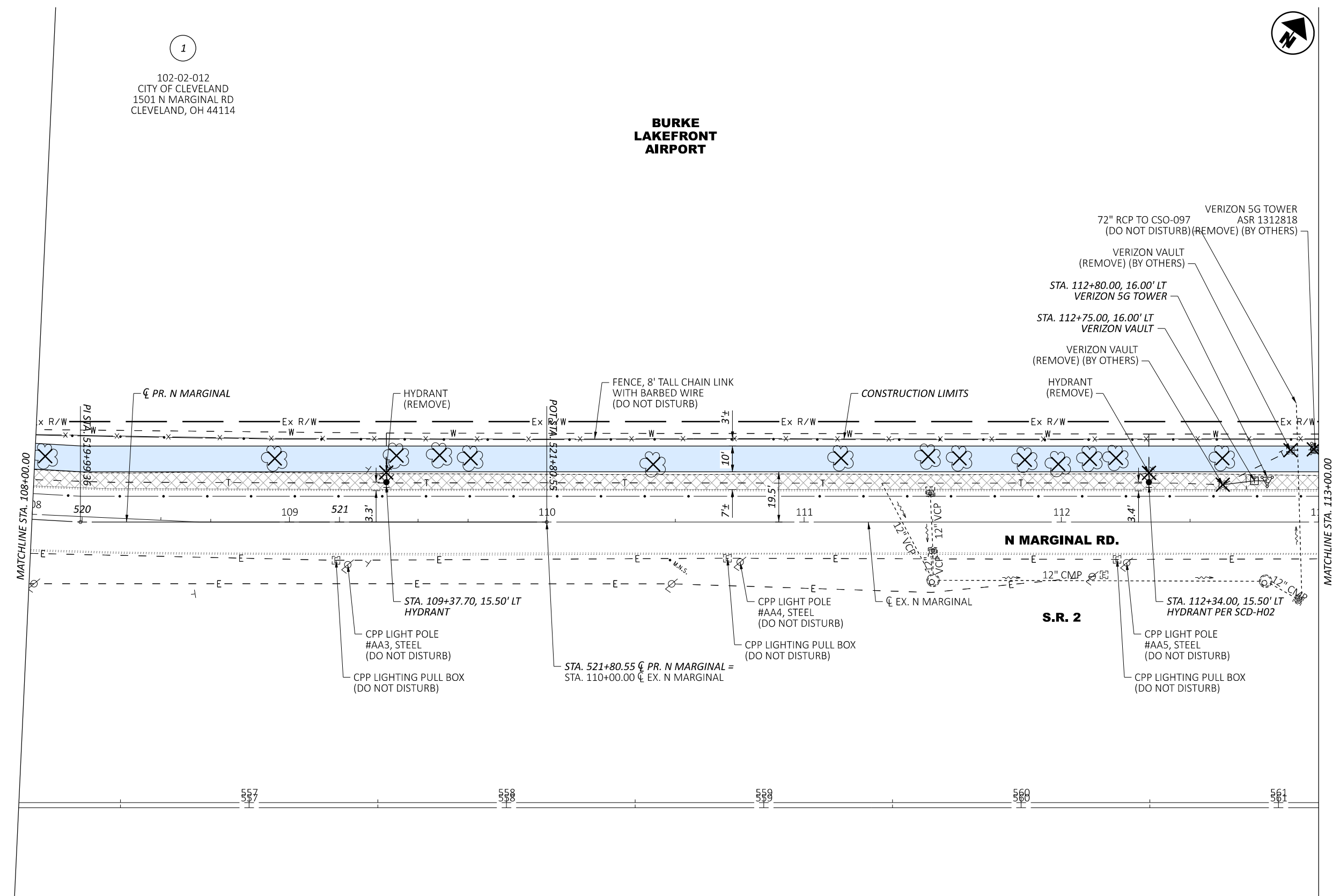

**PLAN - N MARGINAL RD.
 STA. 108+00.00 TO STA. 113+00.00**

LEGEND					
	ASPHALT SHARED-USE PATH		MOMENT SLAB		PAVEMENT REMOVED
	CONCRETE WALK/DRIVE		AGGREGATE DRIVE (ITEM 304)		EX. TREE (DO NOT DISTURB)
	FULL-DEPTH COMPOSITE PVT.		PAVEMENT RESURFACING		EX. TREE (REMOVE)
	ENHANCED DRIVE CROSSING INTEGRALLY COLORED CONCRETE				PR. TREE

DESIGN AGENCY	
Michael Baker INTERNATIONAL	
DESIGNER	---
REVIEWER	---
PROJECT ID	118968
SHEET	38
TOTAL	138

102-02-012
 CITY OF CLEVELAND
 1501 N MARGINAL RD
 CLEVELAND, OH 44114

**BURKE
 LAKEFRONT
 AIRPORT**

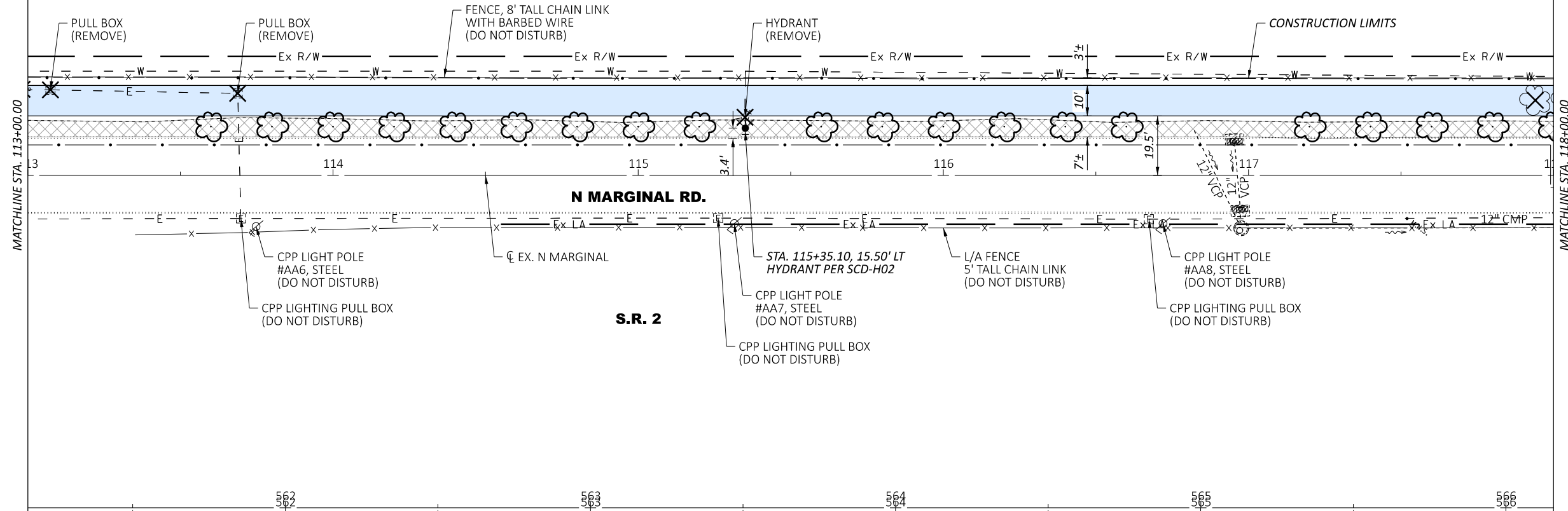

PLAN - N MARGINAL RD.
 STA. 113+00.00 TO STA. 118+00.00

LEGEND		
	ASPHALT SHARED-USE PATH	
	CONCRETE WALK/DRIVE	
	FULL-DEPTH COMPOSITE PVT.	
	ENHANCED DRIVE CROSSING INTEGRALLY COLORED CONCRETE	
	MOMENT SLAB	
	AGGREGATE DRIVE (ITEM 304)	
	PAVEMENT RESURFACING	
	PAVEMENT REMOVED	
	WALK REMOVED	
	EX. TREE (DO NOT DISTURB)	
	EX. TREE (REMOVE)	
	PR. TREE	

DESIGN AGENCY	
Michael Baker INTERNATIONAL	
DESIGNER	---
REVIEWER	---
PROJECT ID	118968
SHEET	39
TOTAL	138

1
 102-02-012
 CITY OF CLEVELAND
 1501 N MARGINAL RD
 CLEVELAND, OH 44114

**BURKE
 LAKEFRONT
 AIRPORT**

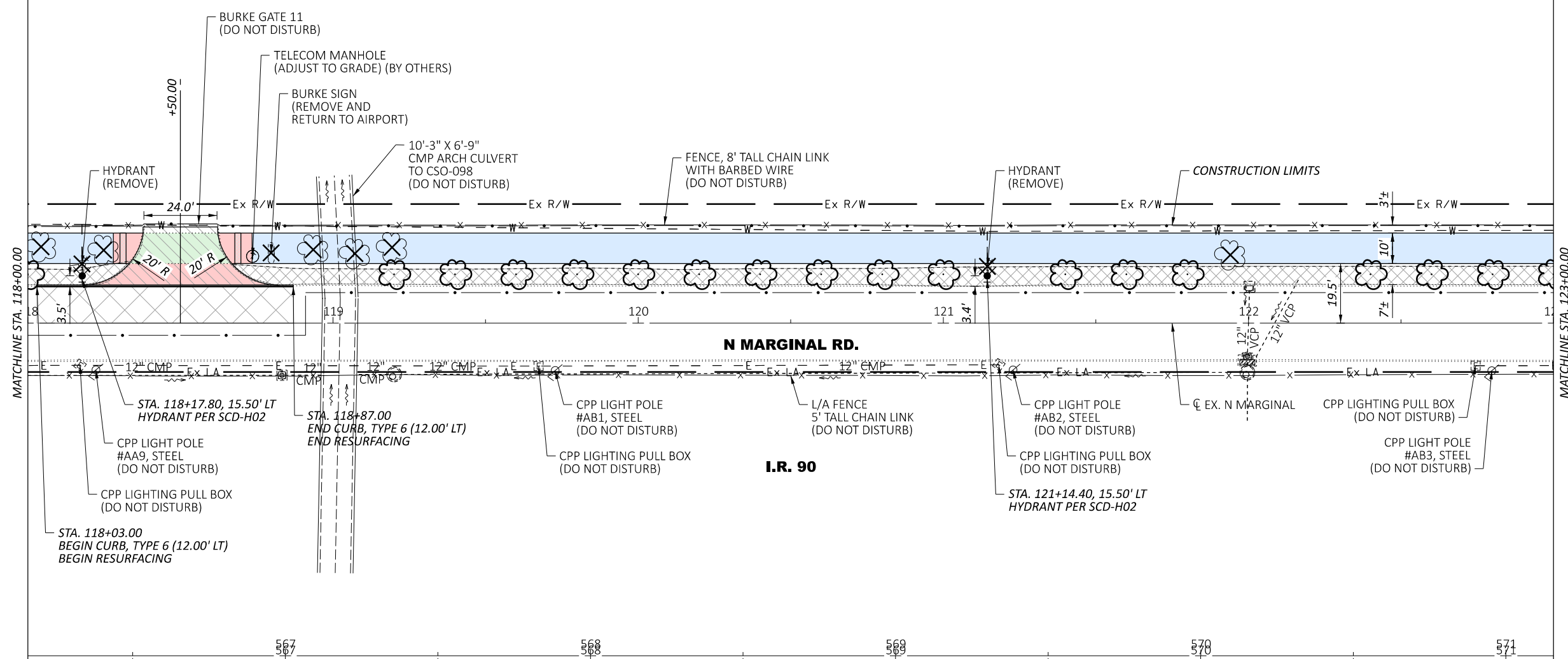
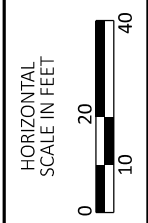

PLAN - N MARGINAL RD.
 STA. 118+00.00 TO STA. 123+00.00

LEGEND			
	ASPHALT SHARED-USE PATH		MOMENT SLAB
	CONCRETE WALK/DRIVE		AGGREGATE DRIVE (ITEM 304)
	FULL-DEPTH COMPOSITE PVT.		PAVEMENT RESURFACING
	ENHANCED DRIVE CROSSING INTEGRALLY COLORED CONCRETE		EX. TREE (DO NOT DISTURB)
			EX. TREE (REMOVE)
			PR. TREE
			PAVEMENT REMOVED
			WALK REMOVED

E. 33RD ST.

DESIGN AGENCY	
DESIGNER	Michael Baker INTERNATIONAL
REVIEWER	---
PROJECT ID	118968
SHEET TOTAL	40 138

1
 102-02-012
 CITY OF CLEVELAND
 1501 N MARGINAL RD
 CLEVELAND, OH 44114

**BURKE
 LAKEFRONT
 AIRPORT**

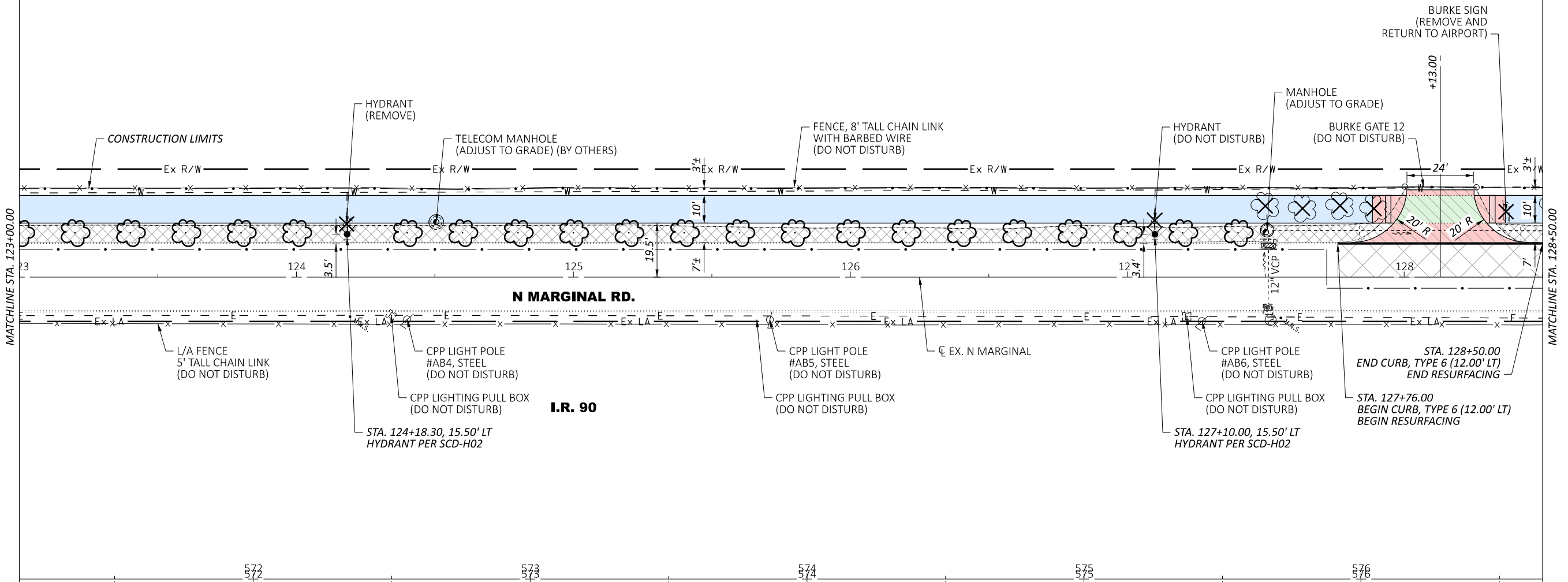

PLAN - N MARGINAL RD.
 STA. 123+00.00 TO STA. 128+50.00

LEGEND			
	ASPHALT SHARED-USE PATH		MOMENT SLAB
	CONCRETE WALK/DRIVE		AGGREGATE DRIVE (ITEM 304)
	FULL-DEPTH COMPOSITE PVT.		PAVEMENT RESURFACING
	ENHANCED DRIVE CROSSING INTEGRALLY COLORED CONCRETE		PAVEMENT REMOVED
			WALK REMOVED
			EX. TREE (DO NOT DISTURB)
			EX. TREE (REMOVE)
			PR. TREE

DESIGN AGENCY	Michael Baker INTERNATIONAL
DESIGNER	---
REVIEWER	---
PROJECT ID	118968
SHEET	41
TOTAL	138

1
 102-02-012
 CITY OF CLEVELAND
 1501 N MARGINAL RD
 CLEVELAND, OH 44114

**BURKE
 LAKEFRONT
 AIRPORT**

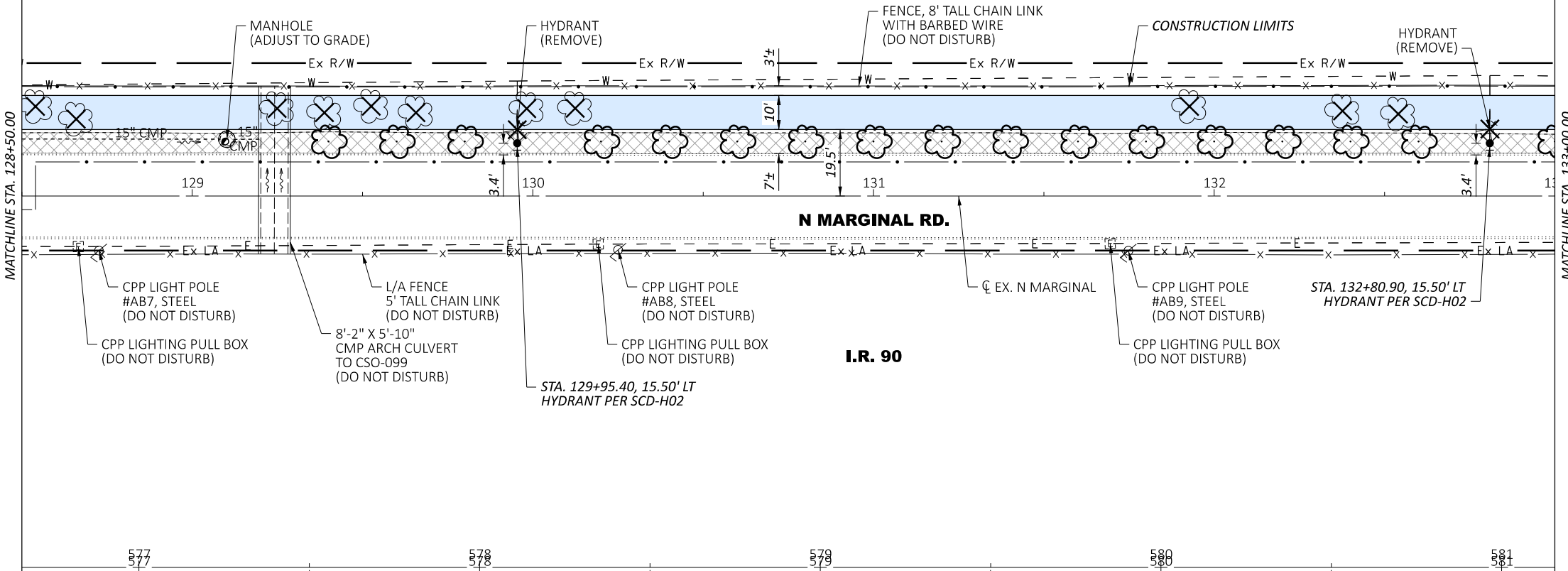

MATCHLINE STA. 128+50.00

MATCHLINE STA. 133+00.00

E. 38TH ST.

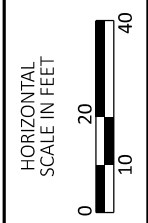

PLAN - N MARGINAL RD.
 STA. 128+50.00 TO STA. 133+00.00

LEGEND					
	ASPHALT SHARED-USE PATH		MOMENT SLAB		PAVEMENT REMOVED
	CONCRETE WALK/DRIVE		AGGREGATE DRIVE (ITEM 304)		EX. TREE (DO NOT DISTURB)
	FULL-DEPTH COMPOSITE PVT.		PAVEMENT RESURFACING		EX. TREE (REMOVE)
	ENHANCED DRIVE CROSSING INTEGRALLY COLORED CONCRETE				PR. TREE

DESIGN AGENCY	
Michael Baker INTERNATIONAL	
DESIGNER	---
REVIEWER	---
PROJECT ID	118968
SHEET	42
TOTAL	138

1
 102-02-012
 CITY OF CLEVELAND
 1501 N MARGINAL RD
 CLEVELAND, OH 44114

**BURKE
 LAKEFRONT
 AIRPORT**

5
 104-01-002A
 CITY OF CLEVELAND
 1150 E 49 ST
 CLEVELAND, OH 44114

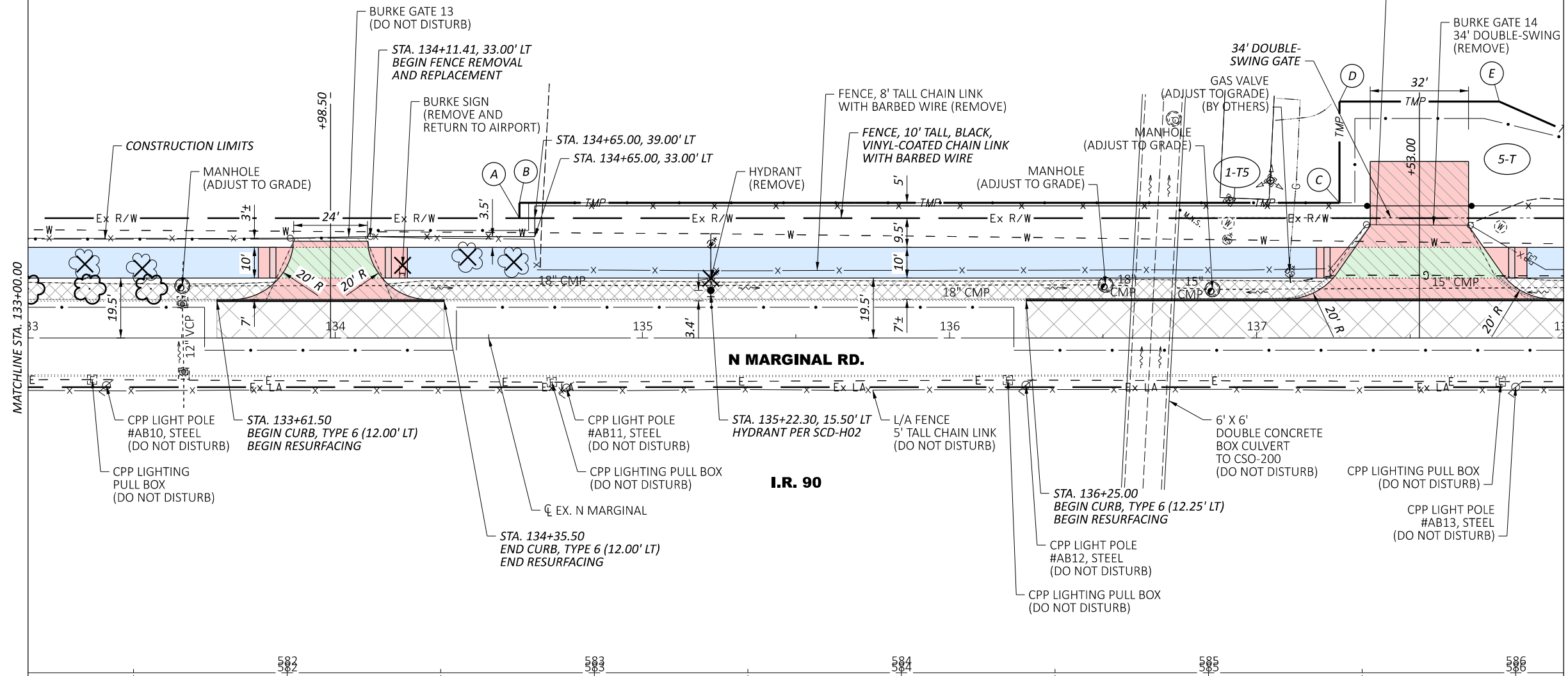

MATCHLINE STA. 133+00.00

MATCHLINE STA. 138+00.00

N MARGINAL RD.

I.R. 90

E. 40TH ST.

	☐ N. MARGINAL RD	OFFSET
A	STA. 134+60.00	39.0' LT
B	STA. 134+60.00	44.0' LT
C	STA. 137+27.00	44.0' LT
D	STA. 137+27.00	77.0' LT
E	STA. 137+79.00	77.0' LT

LEGEND

	ASPHALT SHARED-USE PATH		MOMENT SLAB		PAVEMENT REMOVED
	CONCRETE WALK/DRIVE		AGGREGATE DRIVE (ITEM 304)		EX. TREE (DO NOT DISTURB)
	FULL-DEPTH COMPOSITE PVT.		PAVEMENT RESURFACING		EX. TREE (REMOVE)
	ENHANCED DRIVE CROSSING INTEGRALLY COLORED CONCRETE				PR. TREE

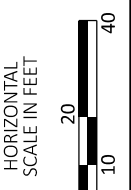

**PLAN - N MARGINAL RD.
 STA. 133+00.00 TO STA. 138+00.00**

DESIGN AGENCY	Michael Baker INTERNATIONAL
DESIGNER	---
REVIEWER	---
PROJECT ID	118968
SHEET	43
TOTAL	138

104-01-002A
 CITY OF CLEVELAND
 1150 E 49 ST
 CLEVELAND, OH 44114

**AIRPORT
 MAINTENANCE
 FACILITY**

**LAKESIDE
 YACHT CLUB**

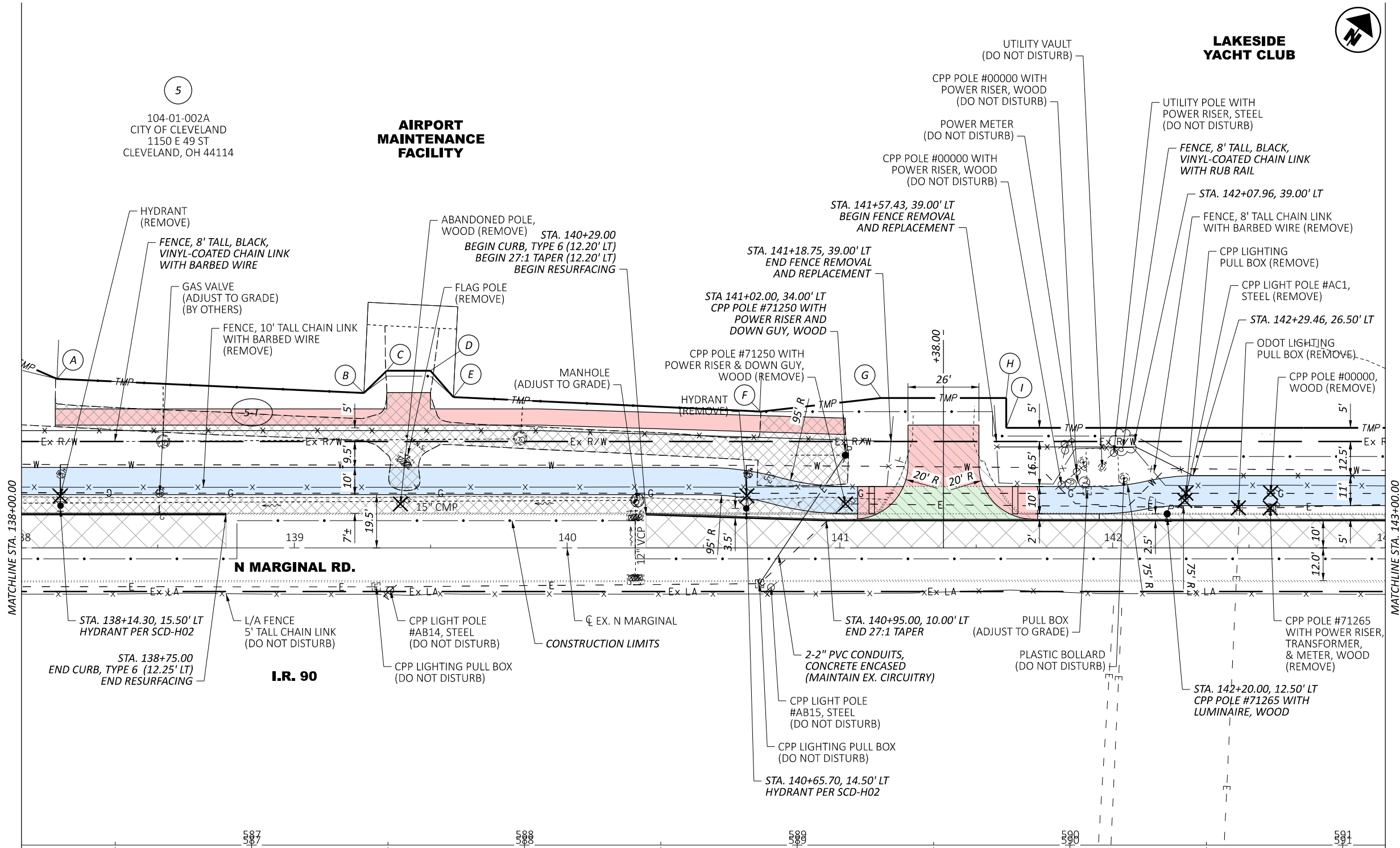

	☐ N. MARGINAL RD	OFFSET
A	STA. 138+12.98	62.0' LT
B	STA. 139+25.51	56.8' LT
C	STA. 139+33.94	65.0' LT
D	STA. 139+49.94	65.0' LT
E	STA. 139+58.31	55.3' LT
F	STA. 140+70.97	50.0' LT
G	STA. 141+15.00	55.0' LT
H	STA. 141+61.00	55.0' LT
I	STA. 141+61.00	44.0' LT

LEGEND		
	ASPHALT SHARED-USE PATH	
	CONCRETE WALK/DRIVE	
	ENHANCED DRIVE CROSSING INTEGRALLY COLORED CONCRETE	
	MOMENT SLAB	
	AGGREGATE DRIVE (ITEM 304)	
	PAVEMENT RESURFACING	
	PAVEMENT REMOVED	
	WALK REMOVED	
	EX. TREE (DO NOT DISTURB)	
	EX. TREE (REMOVE)	
	PR. TREE	



PLAN - N MARGINAL RD.
 STA. 138+00.00 TO STA. 143+00.00

DESIGN AGENCY

**Michael Baker
 INTERNATIONAL**

DESIGNER

REVIEWER

PROJECT ID

118968

SHEET TOTAL

44 138

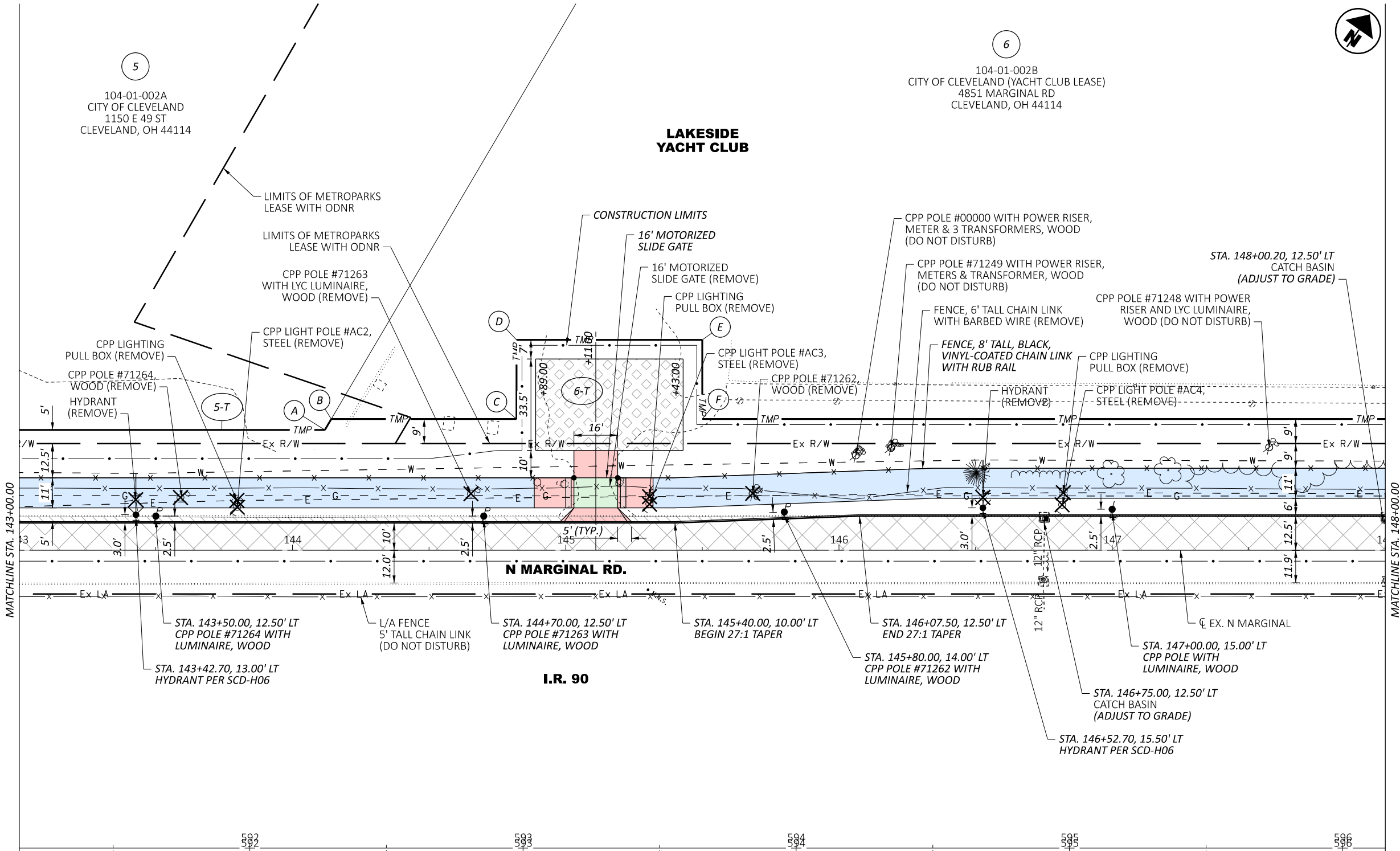

	☐ N. MARGINAL RD	OFFSET
A	STA. 144+11.84	44.0' LT
B	STA. 144+14.19	48.0' LT
C	STA. 144+82.00	48.0' LT
D	STA. 144+82.00	77.0' LT
E	STA. 145+50.00	77.0' LT
F	STA. 145+50.00	48.0' LT

LEGEND		
	ASPHALT SHARED-USE PATH	
	CONCRETE WALK/DRIVE	
	ENHANCED DRIVE CROSSING INTEGRALLY COLORED CONCRETE	
	MOMENT SLAB	
	FULL-DEPTH COMPOSITE PVT.	
	AGGREGATE DRIVE (ITEM 304)	
	PAVEMENT RESURFACING	
	PAVEMENT REMOVED	
	WALK REMOVED	
	EX. TREE (DO NOT DISTURB)	
	EX. TREE (REMOVE)	
	PR. TREE	

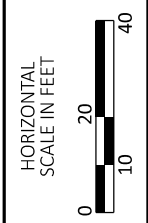

PLAN - N MARGINAL RD.
 STA. 143+00.00 TO STA. 148+00.00

DESIGN AGENCY	Michael Baker International
DESIGNER	---
REVIEWER	---
PROJECT ID	118968
SHEET	45
TOTAL	138

104-01-002B
 CITY OF CLEVELAND (YACHT CLUB LEASE)
 4851 MARGINAL RD
 CLEVELAND, OH 44114

LAKESIDE
 YACHT CLUB

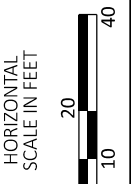
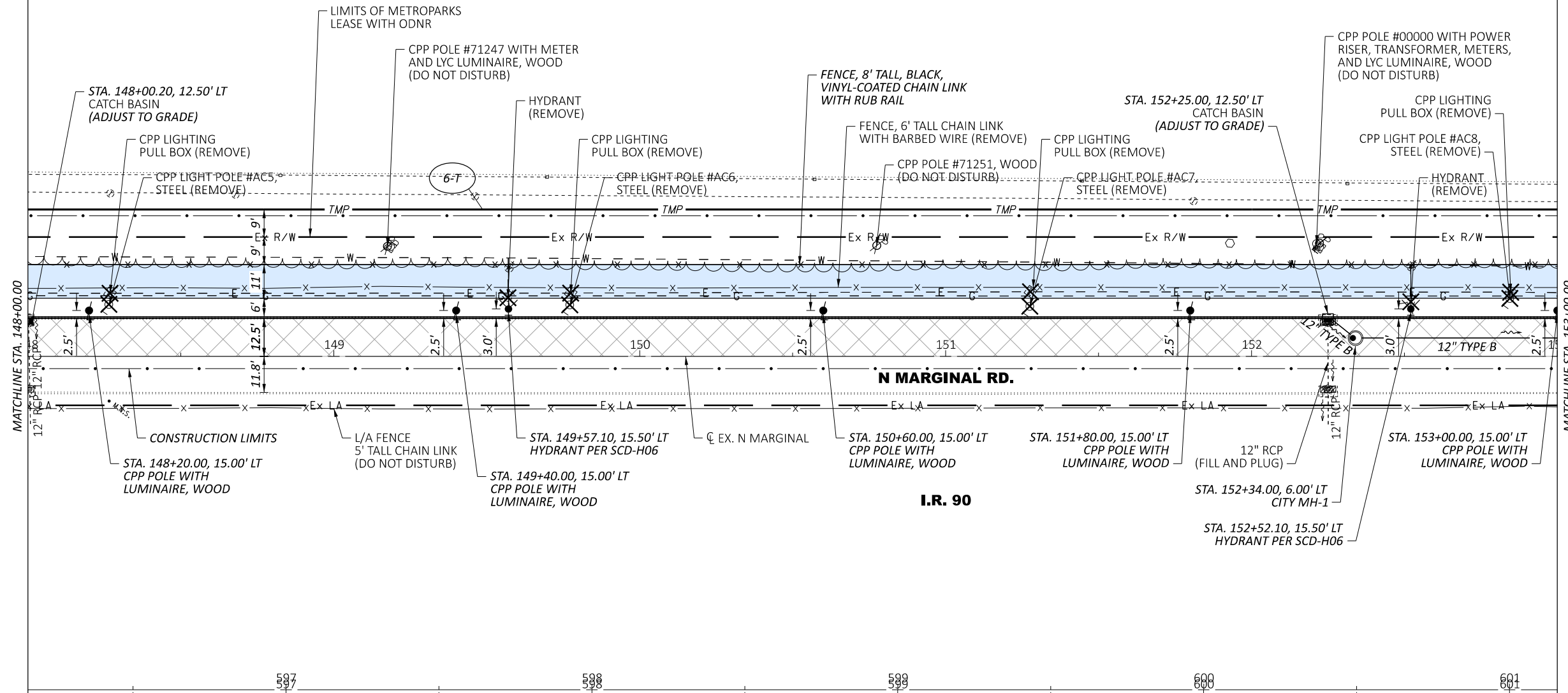

PLAN - N MARGINAL RD.
 STA. 148+00.00 TO STA. 153+00.00

LEGEND					
	ASPHALT SHARED-USE PATH		MOMENT SLAB		PAVEMENT REMOVED
	CONCRETE WALK/DRIVE		AGGREGATE DRIVE (ITEM 304)		WALK REMOVED
	FULL-DEPTH COMPOSITE PVT.		PAVEMENT RESURFACING		EX. TREE (DO NOT DISTURB)
	ENHANCED DRIVE CROSSING INTEGRALLY COLORED CONCRETE				EX. TREE (REMOVE)
					PR. TREE

DESIGN AGENCY

Michael Baker INTERNATIONAL

DESIGNER

REVIEWER

PROJECT ID
 118968

SHEET TOTAL
 46 138

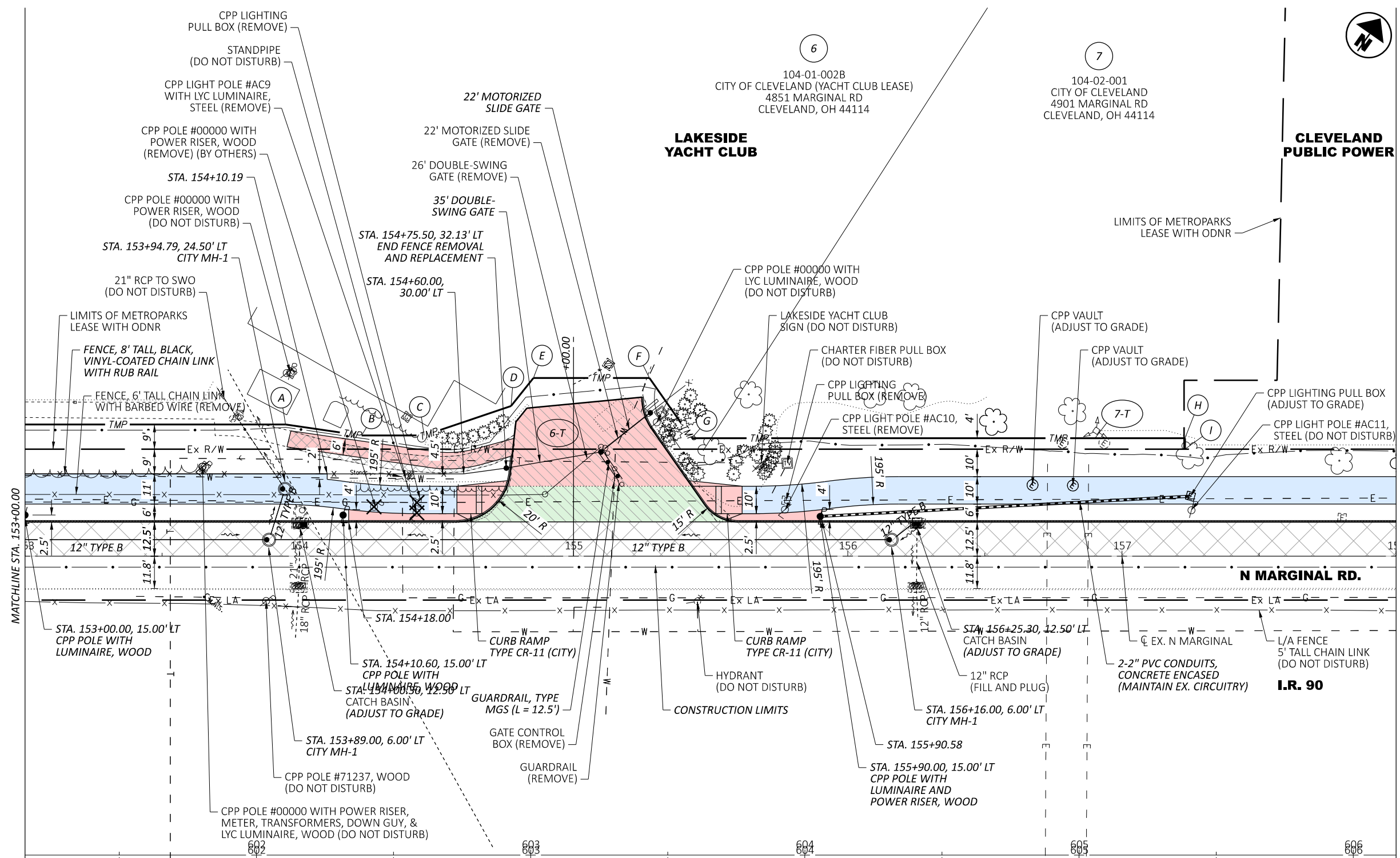

	☐ N. MARGINAL RD	OFFSET
A	STA. 153+95.02	48.0' LT
B	STA. 154+22.76	44.0' LT
C	STA. 154+45.55	44.0' LT
D	STA. 154+77.21	54.8' LT
E	STA. 154+85.40	65.0' LT
F	STA. 155+27.69	65.0' LT
G	STA. 155+43.10	43.0' LT
H	STA. 157+23.00	43.0' LT
I	STA. 157+23.00	39.0' LT

E. 49TH ST.

LEGEND

ASPHALT SHARED-USE PATH	MOMENT SLAB	PAVEMENT REMOVED
CONCRETE WALK/DRIVE	AGGREGATE DRIVE (ITEM 304)	WALK REMOVED
FULL-DEPTH COMPOSITE PVT.	PAVEMENT RESURFACING	EX. TREE (DO NOT DISTURB)
ENHANCED DRIVE CROSSING INTEGRALLY COLORED CONCRETE	PR. TREE	EX. TREE (REMOVE)

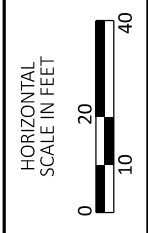

PLAN - N MARGINAL RD.
 STA. 153+00.00 TO STA. 158+00.00

DESIGN AGENCY	Michael Baker International
DESIGNER	---
REVIEWER	---
PROJECT ID	118968
SHEET	47
TOTAL	138

104-02-001
 CITY OF CLEVELAND
 4901 MARGINAL RD
 CLEVELAND, OH 44114

**CLEVELAND
 PUBLIC POWER**

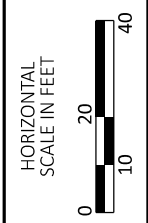
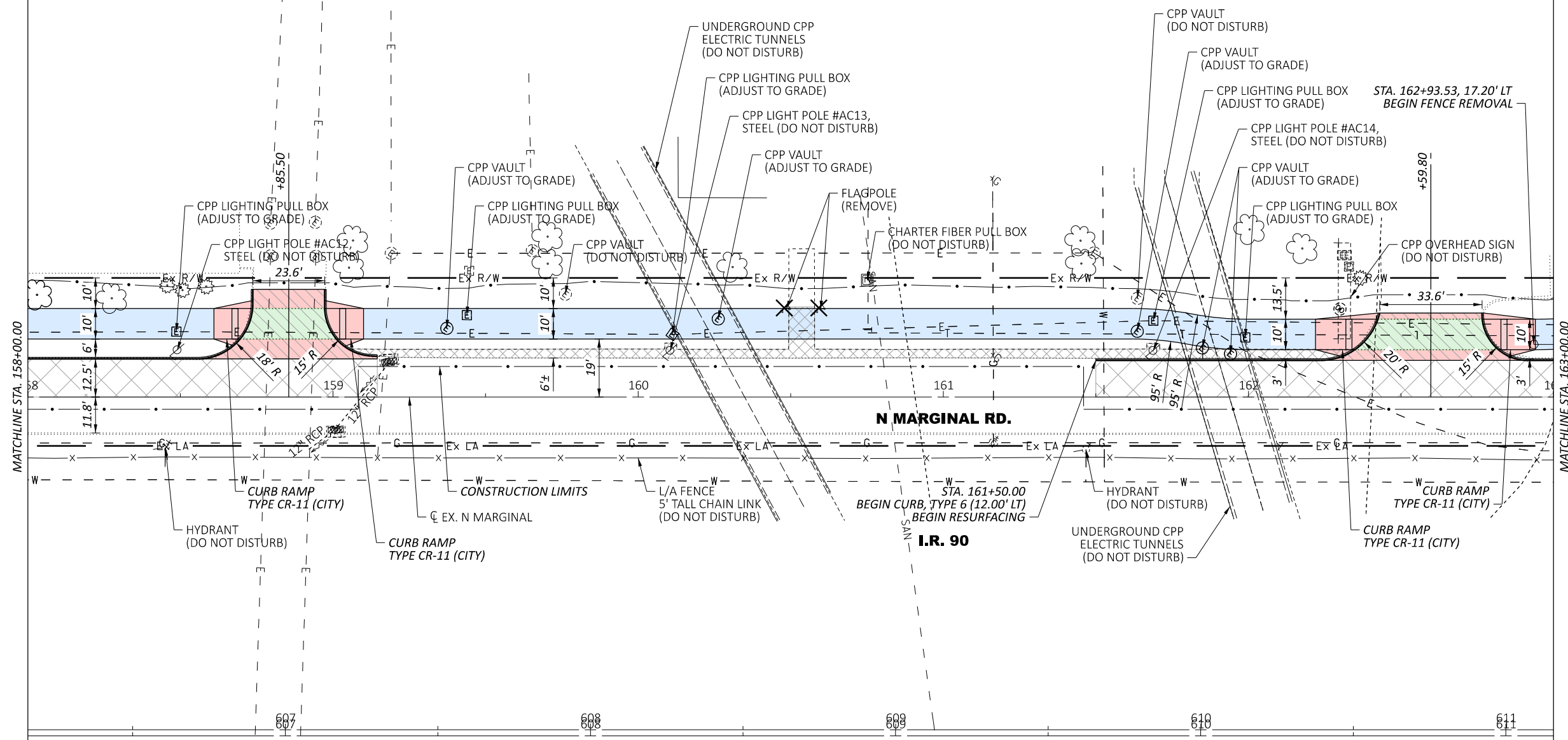

PLAN - N MARGINAL RD.
 STA. 158+00.00 TO STA. 163+00.00

LEGEND		
	ASPHALT SHARED-USE PATH	
	CONCRETE WALK/DRIVE	
	ENHANCED DRIVE CROSSING INTEGRALLY COLORED CONCRETE	
	MOMENT SLAB	
	FULL-DEPTH COMPOSITE PVT.	
	AGGREGATE DRIVE (ITEM 304)	
	PAVEMENT RESURFACING	
	PAVEMENT REMOVED	
	WALK REMOVED	
	EX. TREE (DO NOT DISTURB)	
	EX. TREE (REMOVE)	
	PR. TREE	

DESIGN AGENCY	Michael Baker INTERNATIONAL
DESIGNER	---
REVIEWER	---
PROJECT ID	118968
SHEET	48
TOTAL	138

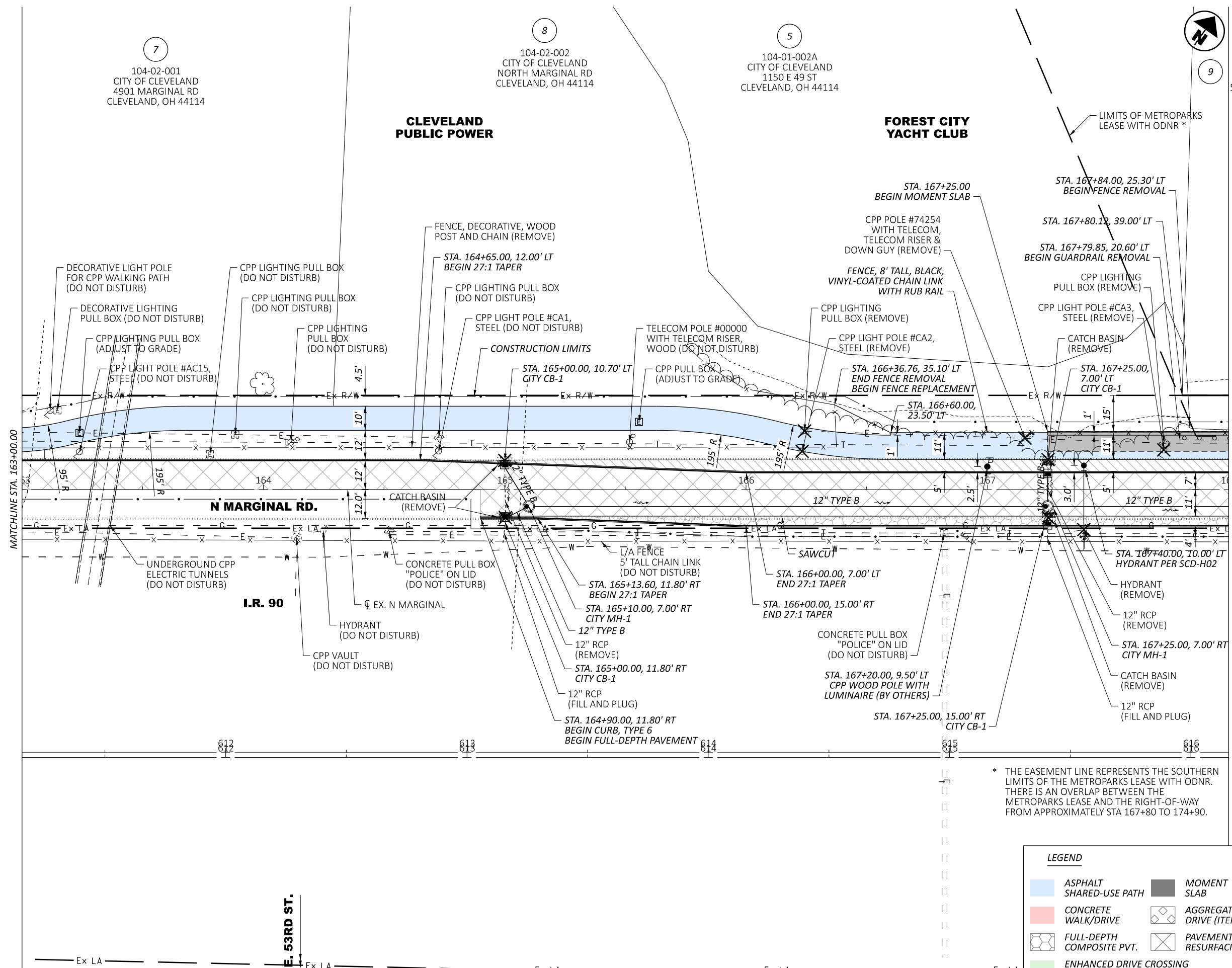

7
 104-02-001
 CITY OF CLEVELAND
 4901 MARGINAL RD
 CLEVELAND, OH 44114

8
 104-02-002
 CITY OF CLEVELAND
 NORTH MARGINAL RD
 CLEVELAND, OH 44114

5
 104-01-002A
 CITY OF CLEVELAND
 1150 E 49 ST
 CLEVELAND, OH 44114

9
 104-01-012A
 CITY OF CLEVELAND
 (FOREST CITY YACHT CLUB)
 5301 NORTH MARGINAL RD
 CLEVELAND, OH 44114

**CLEVELAND
 PUBLIC POWER**

**FOREST CITY
 YACHT CLUB**

LIMITS OF METROPARKS
 LEASE WITH ODNR *

MATCHLINE STA. 163+00.00

MATCHLINE STA. 168+00.00

N MARGINAL RD.

I.R. 90

E. 53RD ST.

* THE EASEMENT LINE REPRESENTS THE SOUTHERN
 LIMITS OF THE METROPARKS LEASE WITH ODNR.
 THERE IS AN OVERLAP BETWEEN THE
 METROPARKS LEASE AND THE RIGHT-OF-WAY
 FROM APPROXIMATELY STA 167+80 TO 174+90.

LEGEND		
	ASPHALT SHARED-USE PATH	
	CONCRETE WALK/DRIVE	
	FULL-DEPTH COMPOSITE PVT.	
	ENHANCED DRIVE CROSSING INTEGRALLY COLORED CONCRETE	
	MOMENT SLAB	
	AGGREGATE DRIVE (ITEM 304)	
	PAVEMENT RESURFACING	
	PAVEMENT REMOVED	
	WALK REMOVED	
	EX. TREE (DO NOT DISTURB)	
	EX. TREE (REMOVE)	
	PR. TREE	



PLAN - N MARGINAL RD.
 STA. 163+00.00 TO STA. 168+00.00

DESIGN AGENCY	Michael Baker INTERNATIONAL
DESIGNER	---
REVIEWER	---
PROJECT ID	118968
SHEET	49
TOTAL	138

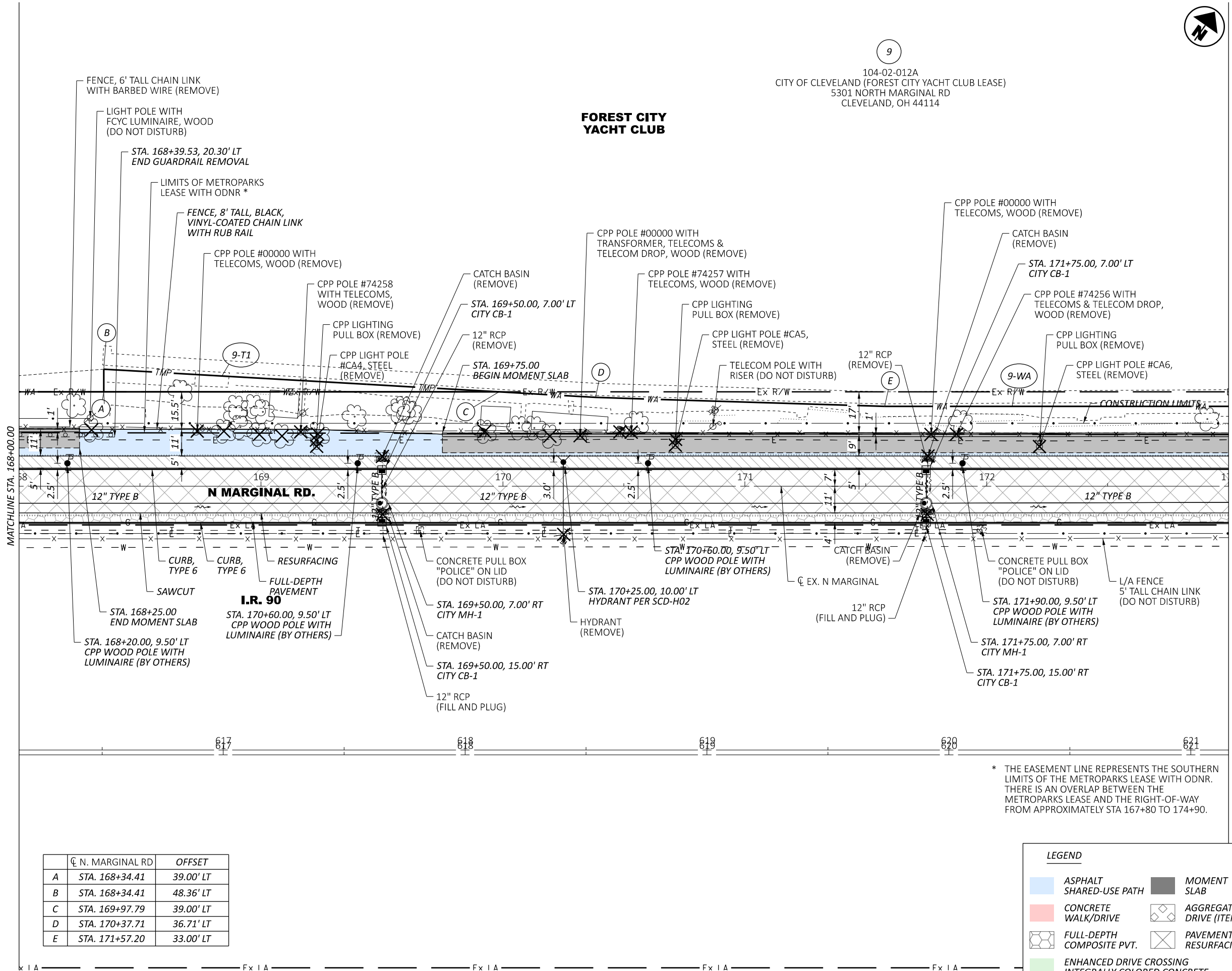

* THE EASEMENT LINE REPRESENTS THE SOUTHERN LIMITS OF THE METROPARKS LEASE WITH ODNR. THERE IS AN OVERLAP BETWEEN THE METROPARKS LEASE AND THE RIGHT-OF-WAY FROM APPROXIMATELY STA 167+80 TO 174+90.

	CL N. MARGINAL RD	OFFSET
A	STA. 168+34.41	39.00' LT
B	STA. 168+34.41	48.36' LT
C	STA. 169+97.79	39.00' LT
D	STA. 170+37.71	36.71' LT
E	STA. 171+57.20	33.00' LT

LEGEND		
	ASPHALT SHARED-USE PATH	
	CONCRETE WALK/DRIVE	
	FULL-DEPTH COMPOSITE PVT.	
	ENHANCED DRIVE CROSSING INTEGRALLY COLORED CONCRETE	
	MOMENT SLAB	
	AGGREGATE DRIVE (ITEM 304)	
	PAVEMENT RESURFACING	
	PAVEMENT REMOVED	
	WALK REMOVED	
	EX. TREE (DO NOT DISTURB)	
	EX. TREE (REMOVE)	
	PR. TREE	



PLAN - N MARGINAL RD.
 STA. 168+00.00 TO STA. 173+00.00

DESIGN AGENCY	Michael Baker INTERNATIONAL
DESIGNER	---
REVIEWER	---
PROJECT ID	118968
SHEET	50
TOTAL	138

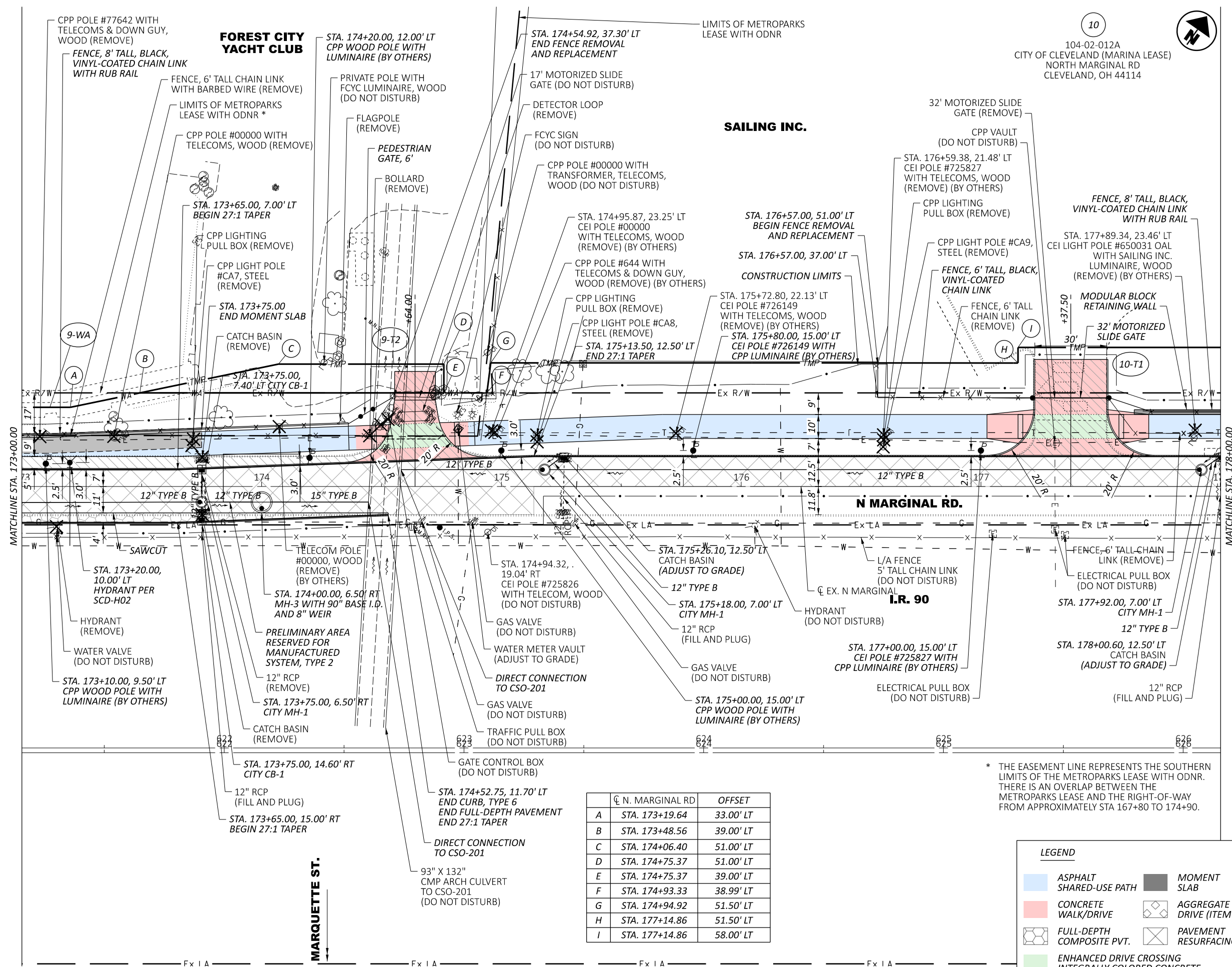

	CL N. MARGINAL RD	OFFSET
A	STA. 173+19.64	33.00' LT
B	STA. 173+48.56	39.00' LT
C	STA. 174+06.40	51.00' LT
D	STA. 174+75.37	51.00' LT
E	STA. 174+75.37	39.00' LT
F	STA. 174+93.33	38.99' LT
G	STA. 174+94.92	51.50' LT
H	STA. 177+14.86	51.50' LT
I	STA. 177+14.86	58.00' LT

* THE EASEMENT LINE REPRESENTS THE SOUTHERN LIMITS OF THE METROPARKS LEASE WITH ODNR. THERE IS AN OVERLAP BETWEEN THE METROPARKS LEASE AND THE RIGHT-OF-WAY FROM APPROXIMATELY STA 167+80 TO 174+90.

LEGEND

	ASPHALT SHARED-USE PATH		MOMENT SLAB		PAVEMENT REMOVED
	CONCRETE WALK/DRIVE		AGGREGATE DRIVE (ITEM 304)		EX. TREE (DO NOT DISTURB)
	FULL-DEPTH COMPOSITE PVT.		PAVEMENT RESURFACING		EX. TREE (REMOVE)
	ENHANCED DRIVE CROSSING INTEGRALLY COLORED CONCRETE				PR. TREE

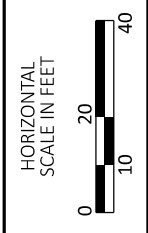

PLAN - N MARGINAL RD.
 STA. 173+00.00 TO STA. 178+00.00

DESIGN AGENCY	Michael Baker International
DESIGNER	---
REVIEWER	---
PROJECT ID	118968
SHEET	51
TOTAL	138

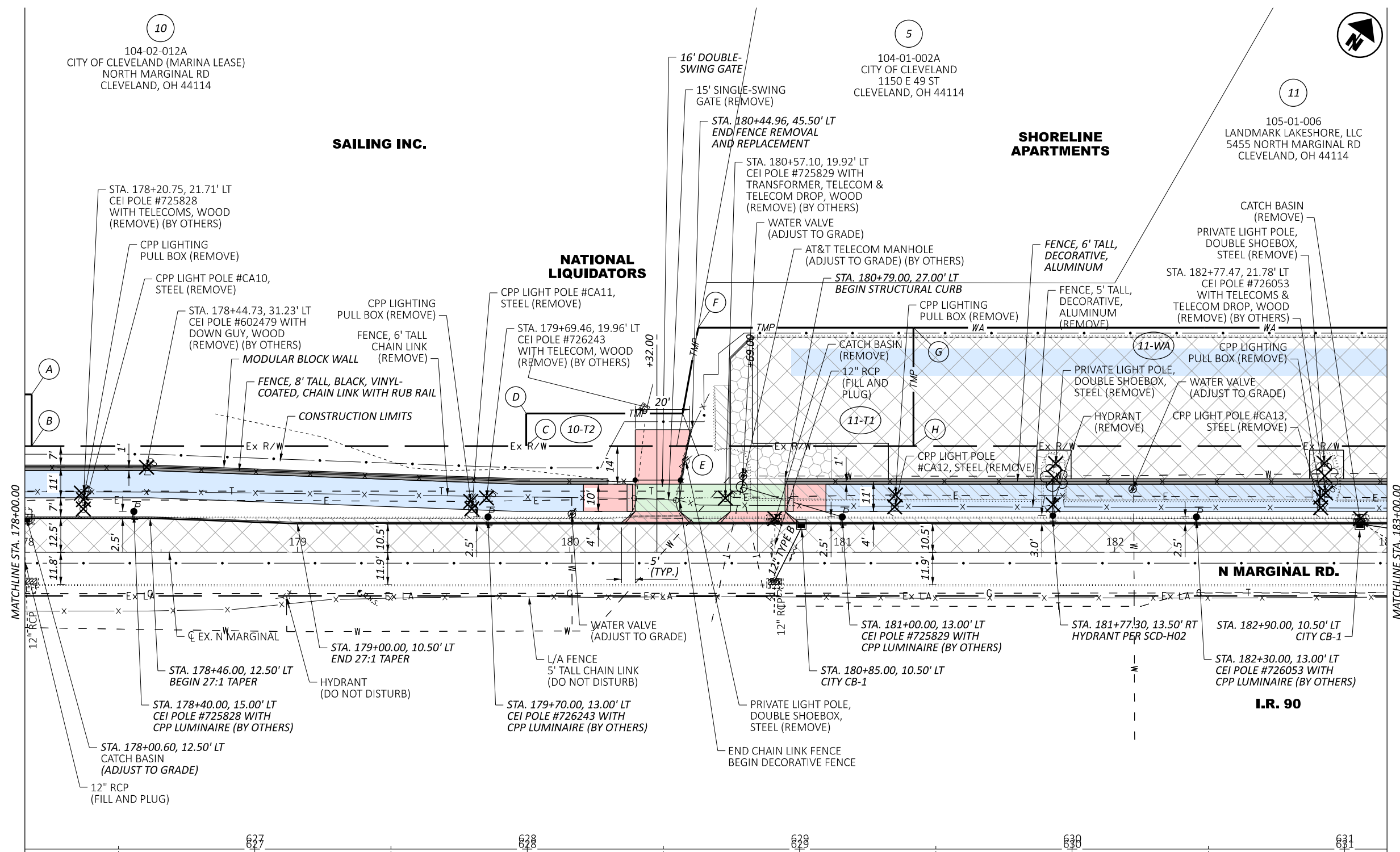

	☉ N. MARGINAL RD	OFFSET
A	STA. 178+02.50	58.0' LT
B	STA. 178+02.50	39.0' LT
C	STA. 179+84.00	39.0' LT
D	STA. 179+84.00	51.0' LT
E	STA. 180+41.43	51.00' LT
F	STA. 180+47.16	82.5' LT
G	STA. 181+26.16	82.5' LT
H	STA. 181+26.16	39.0' LT

LEGEND		
	ASPHALT SHARED-USE PATH	
	CONCRETE WALK/DRIVE	
	FULL-DEPTH COMPOSITE PVT.	
	ENHANCED DRIVE CROSSING INTEGRALLY COLORED CONCRETE	
	MOMENT SLAB	
	AGGREGATE DRIVE (ITEM 304)	
	PAVEMENT RESURFACING	
	PAVEMENT REMOVED	
	WALK REMOVED	
	EX. TREE (DO NOT DISTURB)	
	EX. TREE (REMOVE)	
	PR. TREE	



PLAN - N MARGINAL RD.
 STA. 178+00.00 TO STA. 183+00.00

DESIGN AGENCY	Michael Baker International
DESIGNER	---
REVIEWER	---
PROJECT ID	118968
SHEET	52
TOTAL	138

11
 105-01-006
 LANDMARK LAKESHORE, LLC
 5455 NORTH MARGINAL RD
 CLEVELAND, OH 44114

SHORELINE APARTMENTS

12
 105-01-001
 LANDMARK AT THE LAKE LLC
 5455 NORTH MARGINAL RD
 CLEVELAND, OH 44114

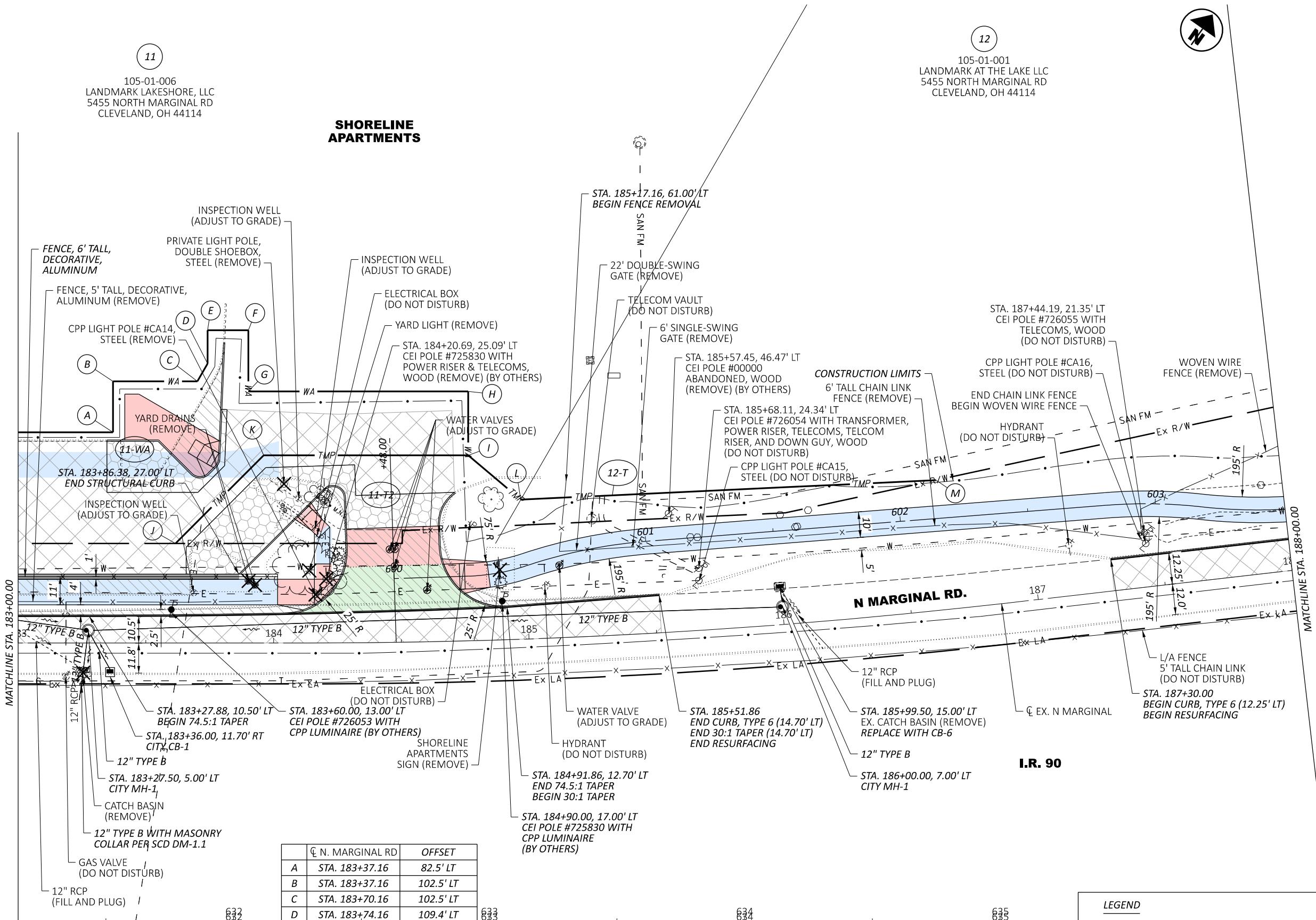

MATCHLINE STA. 183+00.00

MATCHLINE STA. 188+00.00

	☐ N. MARGINAL RD	OFFSET
A	STA. 183+37.16	82.5' LT
B	STA. 183+37.16	102.5' LT
C	STA. 183+70.16	102.5' LT
D	STA. 183+74.16	109.4' LT
E	STA. 183+74.16	122.5' LT
F	STA. 183+90.16	122.5' LT
G	STA. 183+90.16	98.5' LT
H	STA. 184+78.86	97.6' LT
I	STA. 184+78.15	72.6' LT

	☐ N. MARGINAL RD	OFFSET
J	STA. 183+61.61	39.0' LT
K	STA. 183+96.12	73.5' LT
L	STA. 184+98.73	54.7' LT
M	STA. 186+65.04	50.9' LT

LEGEND

	ASPHALT SHARED-USE PATH		MOMENT SLAB		PAVEMENT REMOVED
	CONCRETE WALK/DRIVE		AGGREGATE DRIVE (ITEM 304)		WALK REMOVED
	FULL-DEPTH COMPOSITE PVT.		PAVEMENT RESURFACING		EX. TREE (DO NOT DISTURB)
	ENHANCED DRIVE CROSSING INTEGRALLY COLORED CONCRETE		PR. TREE		EX. TREE (REMOVE)

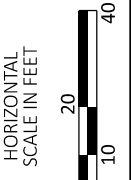

PLAN - N MARGINAL RD.
 STA. 183+00.00 TO STA. 188+00.00

DESIGN AGENCY	Michael Baker INTERNATIONAL
DESIGNER	---
REVIEWER	---
PROJECT ID	118968
SHEET	53
TOTAL	138

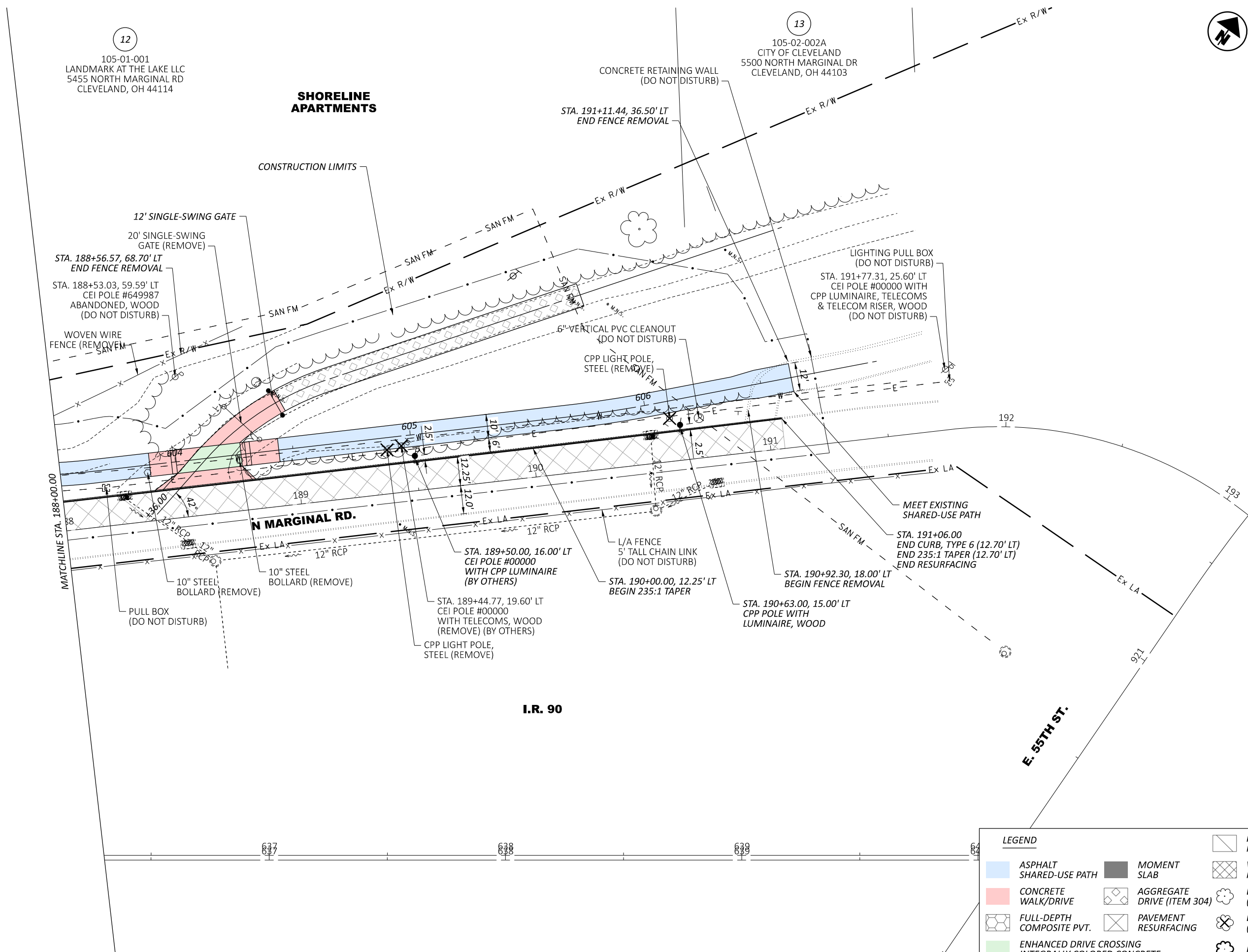

PLAN - N MARGINAL RD.
 STA. 188+00.00 TO STA. 193+00.00

LEGEND			
	ASPHALT SHARED-USE PATH		MOMENT SLAB
	CONCRETE WALK/DRIVE		AGGREGATE DRIVE (ITEM 304)
	ENHANCED DRIVE CROSSING INTEGRALLY COLORED CONCRETE		PAVEMENT RESURFACING
	FULL-DEPTH COMPOSITE PVT.		EX. TREE (DO NOT DISTURB)
	PAVEMENT REMOVED		EX. TREE (REMOVE)
	WALK REMOVED		PR. TREE

DESIGN AGENCY	Michael Baker INTERNATIONAL
DESIGNER	---
REVIEWER	---
PROJECT ID	118968
SHEET	54
TOTAL	138

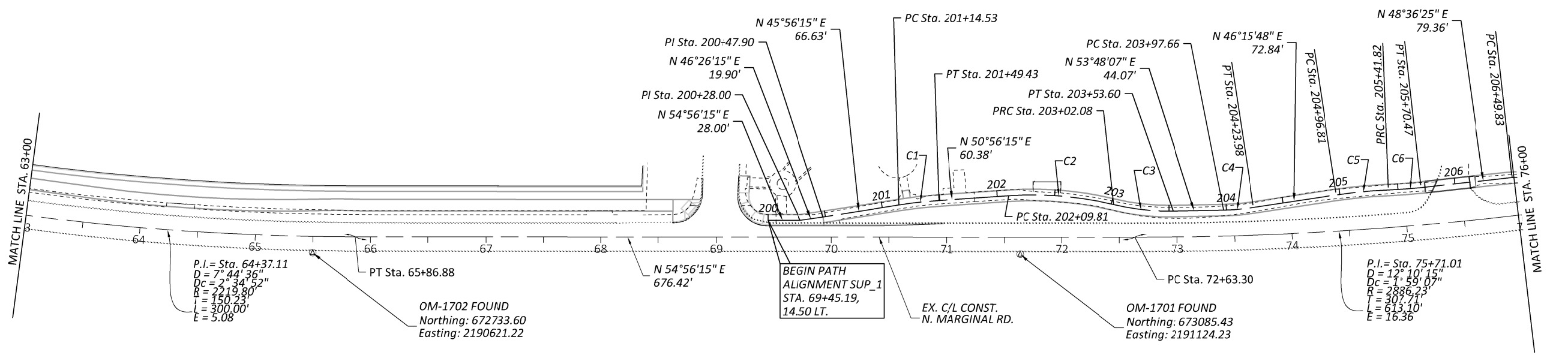
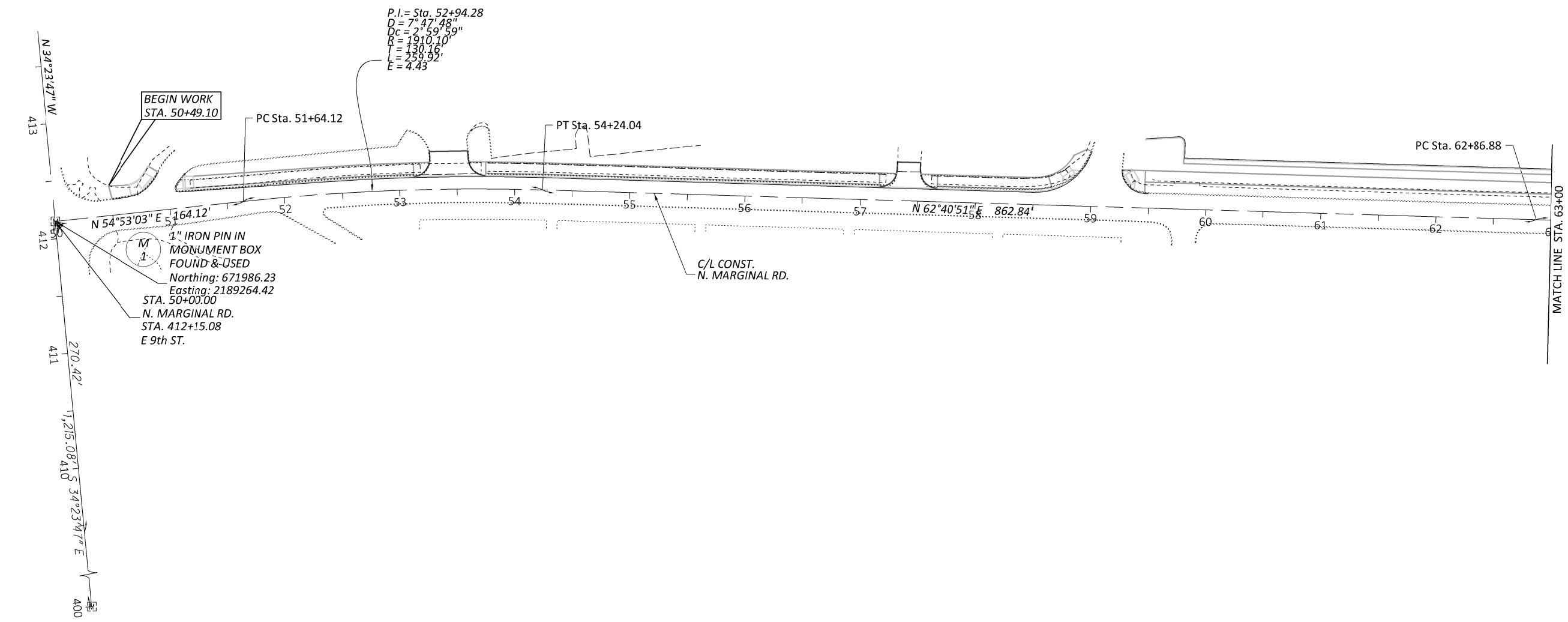

CURVE TABLE							
CURVE	P.I.	DELTA	Dc	R	T	L	E
C1	201+31.99	5°00'00"	14°19'26"	400.00'	17.46'	34.91'	0.38
C2	202+56.31	17°37'19"	19°05'55"	300.00'	46.50'	92.27'	3.58
C3	203+27.98	14°45'28"	28°38'52"	200.00'	25.90'	51.51'	1.67
C4	204+10.84	7°32'19"	28°38'56"	199.99'	13.18'	26.31'	0.43
C5	205+19.34	6°26'48"	14°19'26"	400.00'	22.53'	45.01'	0.63
C6	205+56.15	4°06'12"	14°19'20"	400.04'	14.33'	28.65'	0.26

SYMBOL LEGEND

Exist. Mon. Box

Exist. Mon. Box (Empty)

Exist. Mon. Box with Stone & Drill Hole

Exist. Monument Box ADJUSTED TO GRADE

New Monument Box

ABBREVIATIONS

Centerline C/L

Construction Const.

Right-Of-Way R/W

With Found w/

Iron Pin FND.

Drill Hole I.P.

Monument D.H. MON.

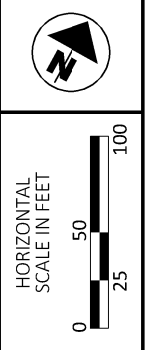

CENTERLINE SCHEMATIC PLAN
N. MARGINAL ROAD - BEGIN PROJECT TO STA. 76+00

DESIGN AGENCY
CVE
CHAGRIN VALLEY ENGINEERING, LTD.
22899 FORBES ROAD, UNIT B
CLEVELAND, OHIO 44146
PHONE: (440) 438-1999
FAX: (440) 438-1969

DESIGNER
RB

REVIEWER
BAK 11/18/22

PROJECT ID
118968

SHEET TOTAL
2 189

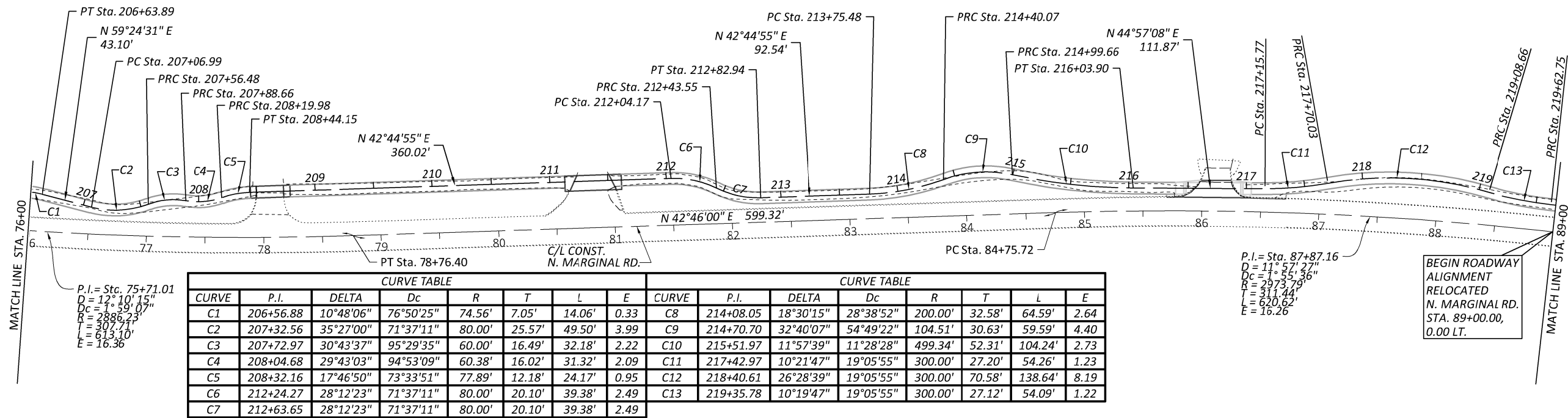

CURVE TABLE							CURVE TABLE								
CURVE	P.I.	DELTA	Dc	R	T	L	E	CURVE	P.I.	DELTA	Dc	R	T	L	E
C1	206+56.88	10°48'06"	76°50'25"	74.56'	7.05'	14.06'	0.33	C8	214+08.05	18°30'15"	28°38'52"	200.00'	32.58'	64.59'	2.64
C2	207+32.56	35°27'00"	71°37'11"	80.00'	25.57'	49.50'	3.99	C9	214+70.70	32°40'07"	54°49'22"	104.51'	30.63'	59.59'	4.40
C3	207+72.97	30°43'37"	95°29'35"	60.00'	16.49'	32.18'	2.22	C10	215+51.97	11°57'39"	11°28'28"	499.34'	52.31'	104.24'	2.73
C4	208+04.68	29°43'03"	94°53'09"	60.38'	16.02'	31.32'	2.09	C11	217+42.97	10°21'47"	19°05'55"	300.00'	27.20'	54.26'	1.23
C5	208+32.16	17°46'50"	73°33'51"	77.89'	12.18'	24.17'	0.95	C12	218+40.61	26°28'39"	19°05'55"	300.00'	70.58'	138.64'	8.19
C6	212+24.27	28°12'23"	71°37'11"	80.00'	20.10'	39.38'	2.49	C13	219+35.78	10°19'47"	19°05'55"	300.00'	27.12'	54.09'	1.22
C7	212+63.65	28°12'23"	71°37'11"	80.00'	20.10'	39.38'	2.49								

CURVE TABLE							
CURVE	P.I.	DELTA	Dc	R	T	L	E
C1	220+37.37	2°50'59"	1°54'35"	3000.00'	74.62'	149.21'	0.93
C2	221+24.86	14°41'44"	57°17'45"	100.00'	12.89'	25.65'	0.83
C3	221+59.51	24°42'44"	57°17'45"	100.00'	21.91'	43.13'	2.37
C4	222+48.01	21°25'45"	16°07'01"	355.50'	67.27'	132.96'	6.31

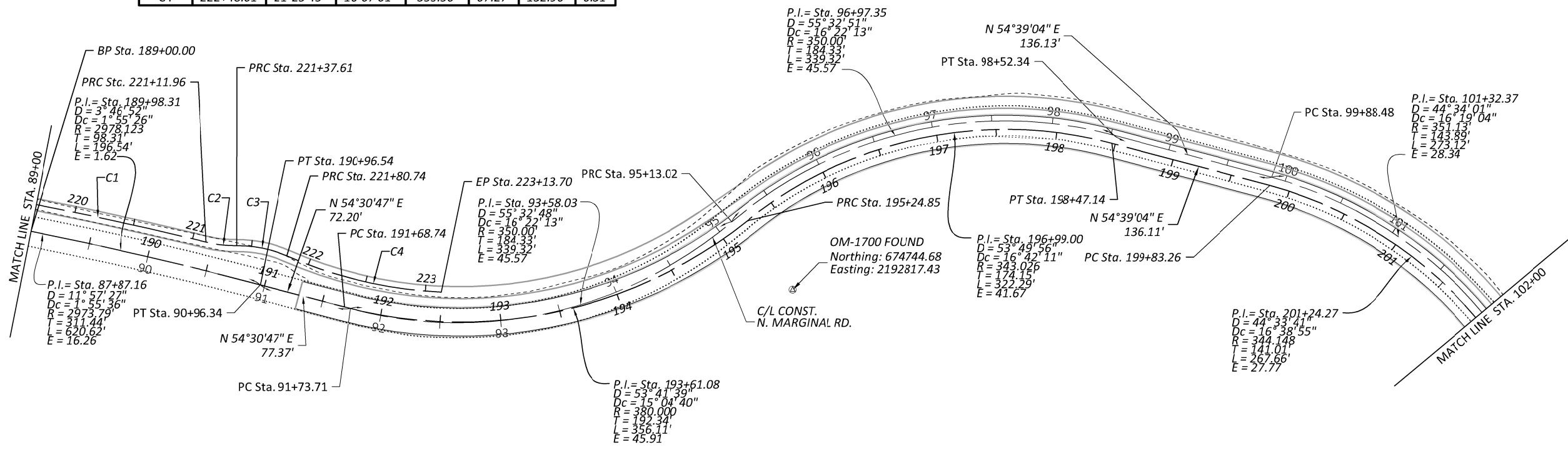

SYMBOL LEGEND

Exist. Mon. Box [Symbol]
 Exist. Mon. Box (Empty) [Symbol]
 Exist. Mon. Box with Stone & Drill Hole [Symbol]
 Exist. Monument Box ADJUSTED TO GRADE [Symbol]
 New Monument Box [Symbol]

ABBREVIATIONS

Centerline Const. C/L Const.
 Right-Of-Way R/W
 With Found w/
 Iron Pin FND.
 Drill Hole I.P.
 Monument D.H. MON.

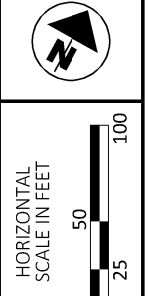

CENTERLINE SCHEMATIC PLAN
N. MARGINAL ROAD - STA. 76+00 TO STA. 102+00

DESIGN AGENCY

 CHAGRIN VALLEY ENGINEERING, LTD.
 22899 FORBES ROAD, UNIT B
 CLEVELAND, OHIO 44146
 PHONE: (440) 438-1999
 FAX: (440) 438-1969

DESIGNER
 RB

REVIEWER
 BAK 11/18/22

PROJECT ID
 118968

SHEET TOTAL
 3 189

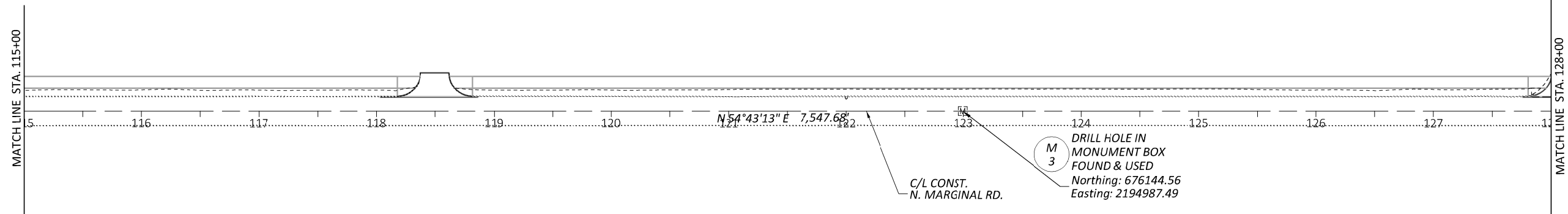
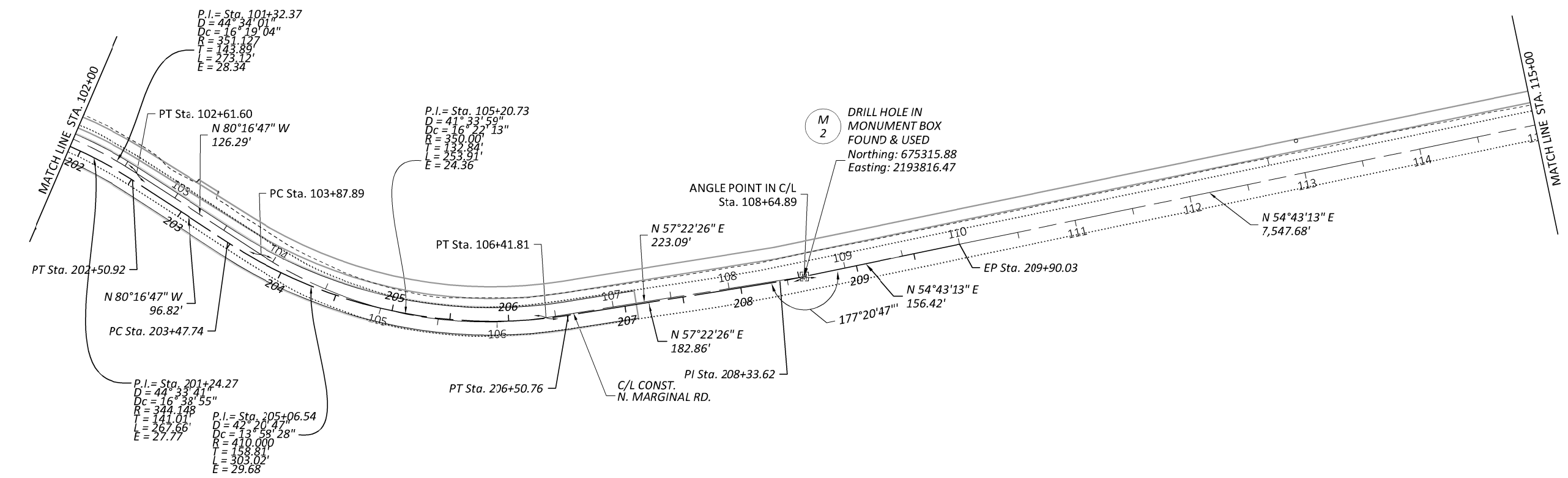

SYMBOL LEGEND

Exist. Monument Box	▣
Exist. Mon. Box (Empty)	□
Exist. Monument Box with Stone & Drill Hole	▣
Exist. Monument Box ADJUSTED TO GRADE	■
New Monument Box	▣

ABBREVIATIONS

Centerline Construction	C/L Const.
Right-Of-Way With Found	R/W w/ FND.
Iron Pin	I.P.
Drill Hole Monument	D.H. MON.

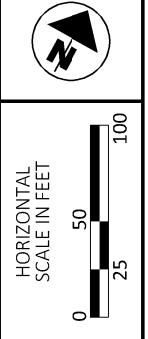

**CENTERLINE SCHEMATIC PLAN
N. MARGINAL ROAD - STA. 102+00 TO STA. 128+00**

DESIGN AGENCY

CVE

CHAGRIN VALLEY ENGINEERING, LTD.
22899 FORBES ROAD, UNIT B
CLEVELAND, OHIO 44146
PHONE: (440) 438-1999
FAX: (440) 438-1969

DESIGNER
RB

REVIEWER
BAK 11/18/22

PROJECT ID
118968

SHEET	TOTAL
4	189

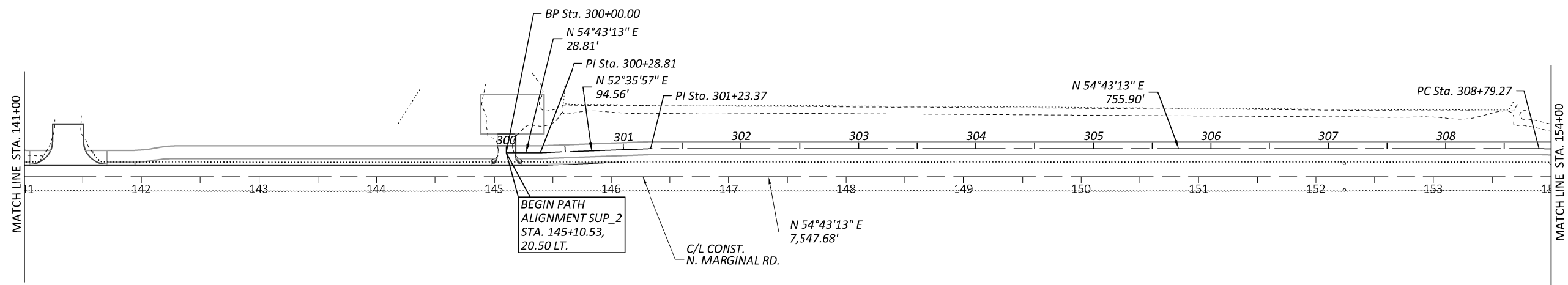
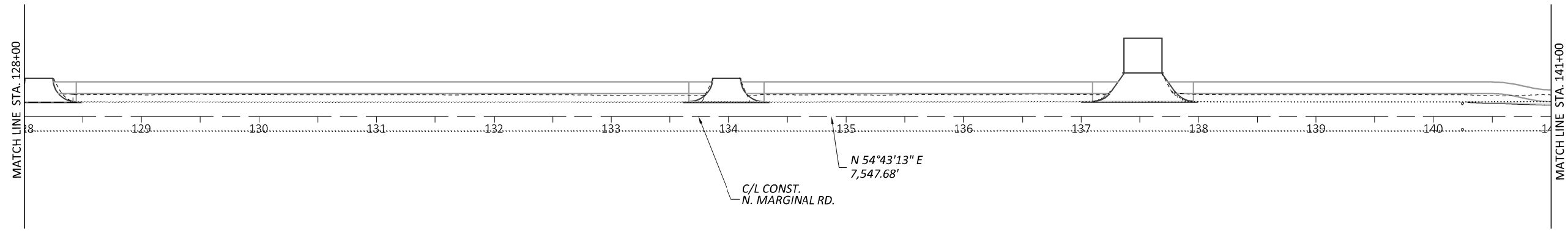

SYMBOL LEGEND

Exist. Monument Box	☒
Exist. Mon. Box (Empty)	☐
Exist. Monument Box with Stone & Drill Hole	☒
Exist. Monument Box ADJUSTED TO GRADE	☒
New Monument Box	☒

ABBREVIATIONS

Centerline	C/L
Construction	Const.
Right-Of-Way	R/W
With Found	w/ FND.
Iron Pin	I.P.
Drill Hole	D.H.
Monument	MON.

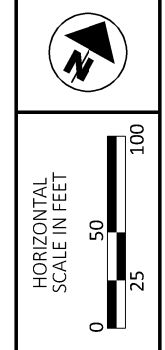

**CENTERLINE SCHEMATIC PLAN
N. MARGINAL ROAD - STA. 128+00 TO STA. 154+00**

DESIGN AGENCY



CHAGRIN VALLEY ENGINEERING, LTD.
22899 FORBES ROAD, UNIT B
CLEVELAND, OHIO 44146
PHONE: (440) 438-1999
FAX: (440) 438-1969

DESIGNER
RB

REVIEWER
BAK 11/18/22

PROJECT ID
118968

SHEET	TOTAL
5	189

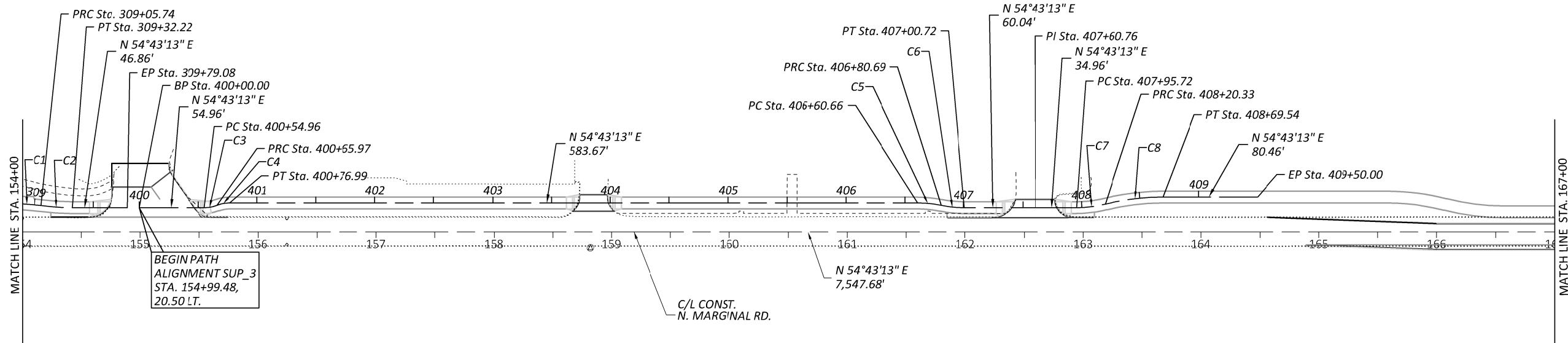

CURVE TABLE							
CURVE	P.I.	DELTA	Dc	R	T	L	E
C1	308+92.52	7°35'06"	28°38'52"	200.00'	13.26'	26.48'	0.44
C2	309+19.00	7°35'06"	28°38'52"	200.00'	13.26'	26.48'	0.44
C3	400+60.53	21°02'22"	190°59'09"	30.00'	5.57'	11.02'	0.51
C4	400+71.54	21°02'22"	190°59'09"	30.00'	5.57'	11.02'	0.51
C5	406+70.71	11°28'42"	57°17'45"	100.00'	10.05'	20.03'	0.50
C6	406+90.74	11°28'42"	57°17'45"	100.00'	10.05'	20.03'	0.50
C7	408+08.09	14°05'51"	57°17'45"	100.00'	12.36'	24.60'	0.76
C8	408+45.06	14°05'51"	28°38'52"	200.00'	24.73'	49.21'	1.52

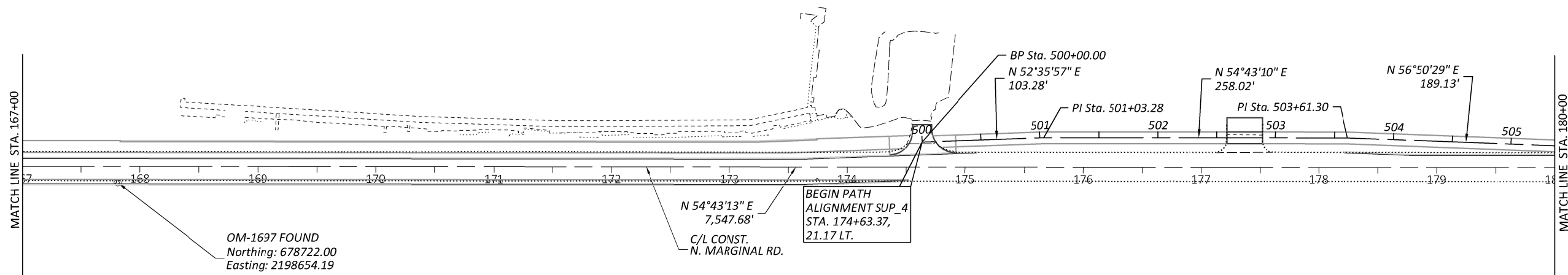

OM-1697 FOUND
 Northing: 678722.00
 Easting: 2198654.19

SYMBOL LEGEND

Exist. Mon. Box

Exist. Mon. Box (Empty)

Exist. Mon. Box with Stone & Drill Hole

Exist. Monument Box ADJUSTED TO GRADE

New Monument Box

ABBREVIATIONS

Centerline C/L

Construction Const.

Right-Of-Way R/W

With Found w/

Iron Pin FND.

Drill Hole I.P.

Monument D.H. MON.

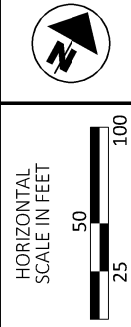

CENTERLINE SCHEMATIC PLAN
 N. MARGINAL ROAD - STA. 154+00 TO STA. 180+00

DESIGN AGENCY



DESIGNER

RB

REVIEWER

BAK 11/18/22

PROJECT ID

118968

SHEET TOTAL

6 189

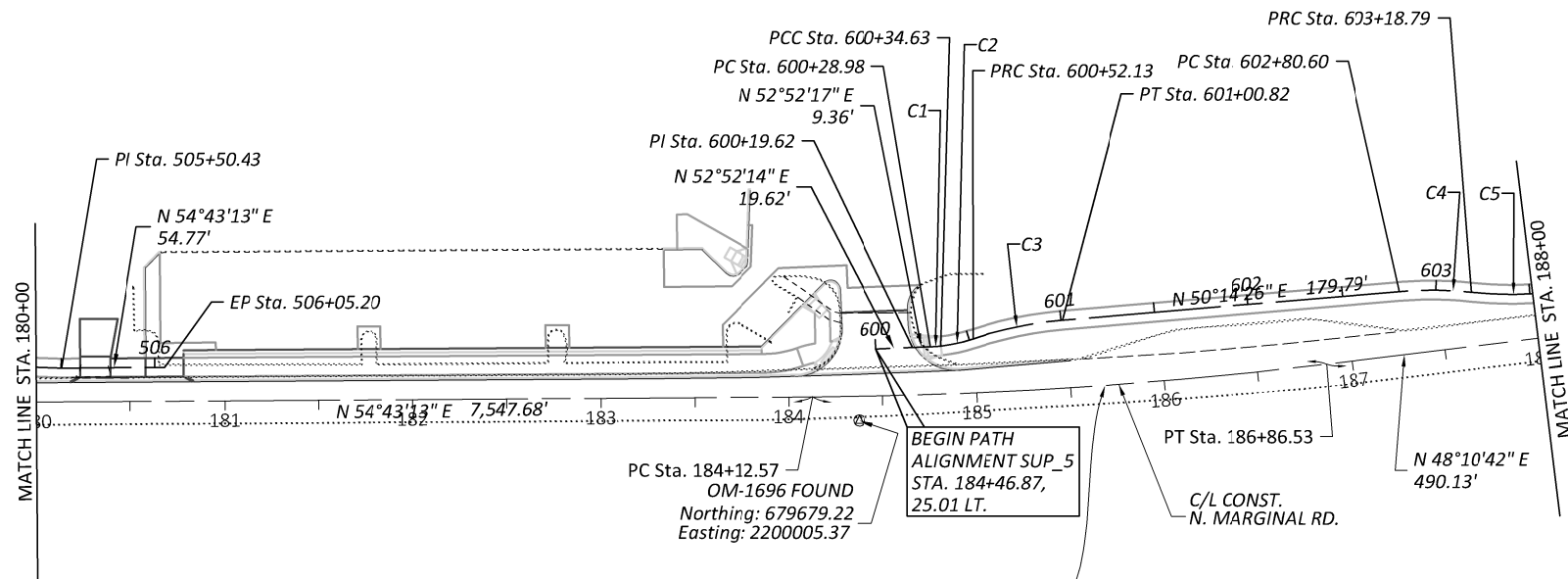

P.I. = Sta. 185+49.70
 D = 6°32'25"
 Dc = 2°23'14"
 R = 2400.01'
 L = 137.13'
 T = 273.96'
 E = 3.91'

CURVE TABLE							
CURVE	P.I.	DELTA	Dc	R	T	L	E
C1	600+31.81	4°02'40"	71°37'11"	80.00'	2.82'	5.65'	0.05
C2	600+43.42	12°32'03"	71°37'11"	80.00'	8.79'	17.50'	0.48
C3	600+76.59	13°56'51"	28°38'52"	200.00'	24.46'	48.69'	1.49
C4	602+99.76	10°56'28"	28°38'52"	200.00'	19.15'	38.19'	0.92
C5	603+41.59	13°00'11"	28°38'52"	200.00'	22.79'	45.39'	1.29

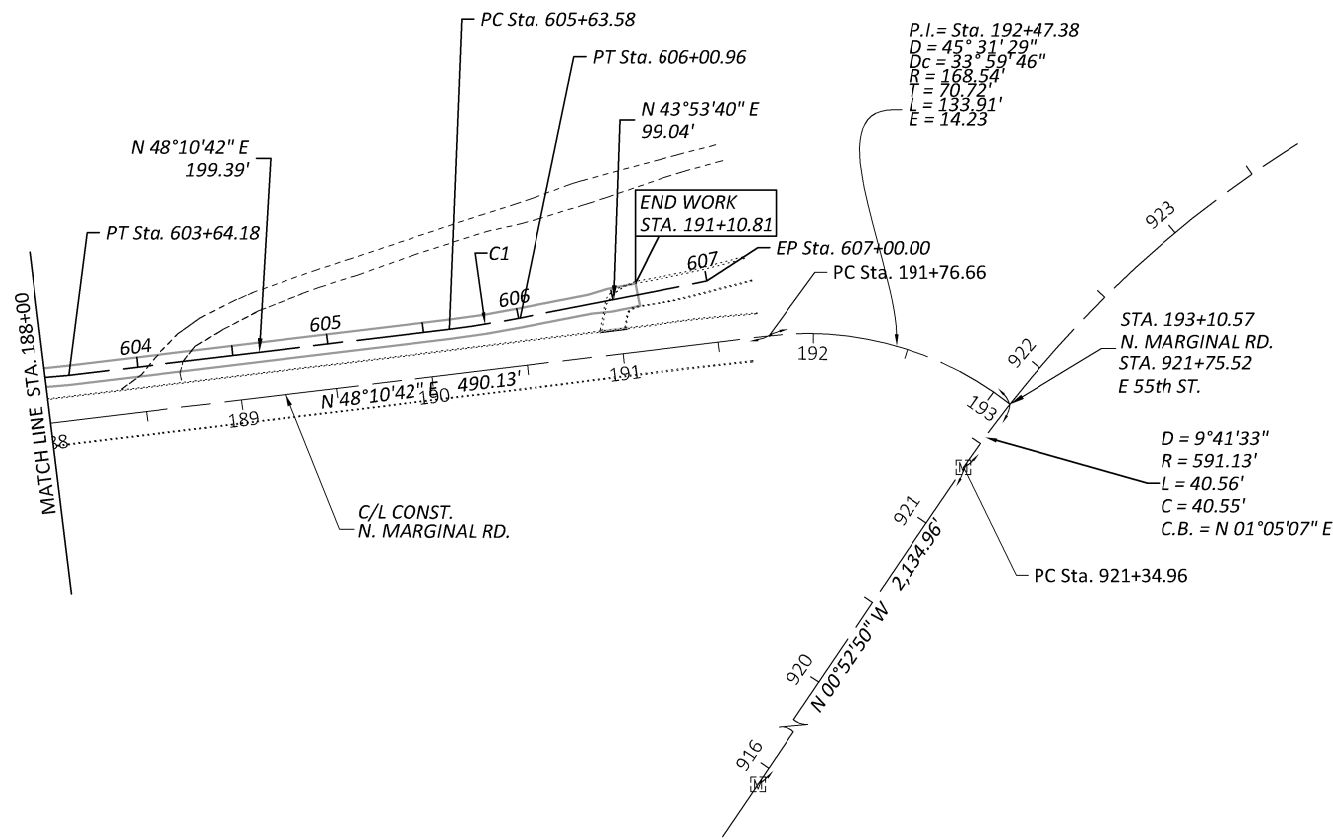

P.I. = Sta. 192+47.38
 D = 45°31'29"
 Dc = 33°59'46"
 R = 168.54'
 L = 70.72'
 T = 133.91'
 E = 14.23'

CURVE TABLE							
CURVE	P.I.	DELTA	Dc	R	T	L	E
C1	605+82.28	4°17'03"	11°27'33"	500.00'	18.70'	37.39'	0.35

PROJECT CONTROL POINTS
 HORIZONTAL CONTROL POINTS & BOUNDARY MONUMENTS

SURVEY PROJECT CONTROL TABLE				
Point #	Northing	Easting	Elevation	Raw Description
101	676647.9130	2195660.6290	581.490	IPINS
102	677195.2500	2196498.4990	580.720	IPID
103	677751.5150	2197283.4950	581.710	IPINS
104	678202.7410	2197920.0540	584.370	GOVCON
105	678722.0050	2198654.1930	583.430	GOVCON
106	679173.4270	2199241.2950	581.690	IPINS
107	679679.2230	2200005.3670	579.070	GOVCON
108	680180.1250	2200625.6190	601.640	MAG
109	675149.7550	2193025.1410	583.560	MAGS
110	674744.6850	2192817.4340	597.980	GOVCON
111	674416.9960	2192576.7690	582.460	IPINS

EXISTING CENTERLINE CONTROL POINTS

SURVEY PROJECT CONTROL TABLE				
Point #	Northing	Easting	Elevation	Raw Description
100	675315.8810	2193816.4670	581.290	MONBOX
118	671986.2340	2189264.4190	596.220	MONBOX
120	676144.5560	2194987.4900	580.340	MONBOX
202	670983.5070	2189950.7360	642.853	MONBOX
203	671406.4310	2190564.3400	635.048	MONBOX
213	679627.4060	2200535.7500	599.199	MONBOX
214	679576.7740	2200321.5080	587.962	MONBOX
215	679368.5580	2199921.8550	578.320	MONBOX
216	678929.9140	2199300.5990	581.128	MONBOX
217	680174.6750	2200679.6490	601.866	MONBOX
218	679629.8210	2200688.1830	603.084	MONBOX
220	679148.8300	2200645.5350	604.169	MONBOX
221	678232.0670	2198312.5420	586.423	MONBOX
222	677887.2870	2197900.9140	582.103	MONBOX
223	677770.9160	2197736.6380	580.666	MONBOX

SYMBOL LEGEND
 Exist. Mon. Box [Symbol]
 Exist. Mon. Box (Empty) [Symbol]
 Exist. Mon. Box with Stone & Drill Hole [Symbol]
 Exist. Mon. Box ADJUSTED TO GRADE [Symbol]
 New Monument Box [Symbol]

ABBREVIATIONS
 Centerline Construction [Symbol]
 Right-Of-Way With Found Iron Pin [Symbol]
 Drill Hole Monument [Symbol]

C/L Const.
 R/W w/ FND. I.P.
 D.H. MON.

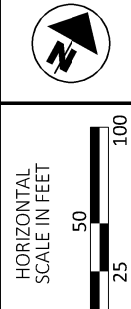

CENTERLINE SCHEMATIC PLAN
 N. MARGINAL ROAD - STA. 180+00 TO END PROJECT

DESIGN AGENCY
CVE
 CHAGRIN VALLEY ENGINEERING, LTD.
 22899 FORBES ROAD, UNIT B
 CLEVELAND, OHIO 44146
 PHONE: (440) 438-1999
 FAX: (440) 438-1969

DESIGNER
 RB

REVIEWER
 BAK 11/18/22

PROJECT ID
 118968

SHEET TOTAL
 7 189

Seeking Authority to Acquire Right-of-Way for the North Marginal Rd Connector Project

Scope of Work Summary

This Legislative Action Request does not involve a contract.

The Department of Public Works is seeking the following in connection with North Marginal Rd Connector Project:

- (1) approval of the Right-of-Way Plans M-5052
- (2) authority to acquire required right-of-way; and
- (3) ruling that special assessments are not to be levied and collected to pay any part of the County's costs of these improvements.

Since June 21, 2023 and continuing until the Resolution granting the requested action is either adopted or rejected, the Department of Public Works has posted and provided continuous notice of the following on its website:

- The Department of Public Works has submitted the Project's Right of Way Property Plans M-5052 for County Council approval and that the same are available for viewing on said website;
- The Department of Public Works intends to acquire right-of-way for said improvement;
- That a First Reading of the Resolution approving the revised right-of-way plans will be made by the Cuyahoga County Council at its meeting scheduled to begin at 5:00 p.m. on July 18, 2022; and,
- That general public access and ability to review the right-of-way plans via an electronic link as indicated.

There are a total of 4 ownerships and 20 parcels associated with the acquisition of right-of-way for this project. The City of Cleveland owns 15 of the parcels.

- a. The primary goal of this project is to obtain Council's review and approval of the right-of-way plans and approval of the required acquisitions needed for the North Marginal Rd Connector Project
Location: City of Cleveland along North Marginal between East 9th to East 55th Street.
- b. District 7

Project Status

Acquisition must be completed in 2023. The Project is anticipated for construction in 2024.

Funding

The project is to be funded with \$5,684,048 Federal (47%), \$5,700,000 Cleveland/Cleveland Metroparks (47%), \$700,000 County Road and Bridge (6%). The total cost of the project is \$12,084,048. \$150,000.00 – Right of Way

County Council of Cuyahoga County, Ohio

Resolution No. R2023-0211

Sponsored by: County Executive Ronayne/Department of Public Works	A Resolution fixing the 2024 water, storm and sanitary sewer maintenance and/or sewerage treatment rates for County Sewer District Nos. 1, 1A, 2, 3, 5, 8, 9, 13, 14, 18, 20, 21, 22 and 24, in accordance with Ohio Revised Code Section 6117.02; and declaring the necessity that this Resolution become immediately effective.
--	--

WHEREAS, the County Executive/Department of Public Works/County Sanitary Engineer recommends fixing water, storm and sanitary sewer maintenance and/or sewerage treatment rates for the County Sewer District Nos. 1, 1A, 2, 3, 5, 8, 9, 13, 14, 18, 20, 21, 22 and 24 for Fiscal 2024; and

WHEREAS, the County has contractual obligations with communities to operate and maintain water lines and sewerage systems including storm sewers, sanitary sewers, wastewater treatment plants, and pumping stations; and

WHEREAS, the funds are necessary to pay for the treatment and disposal costs, and for proper maintenance and operation of the water lines and sewerage systems in said districts for Fiscal 2024; and

WHEREAS, in accordance with the Ohio Revised Code Section 6117.02, the County may levy an assessment to pay the cost and expense of the maintenance and operation of such improvements, including the disposal of sewage; and

WHEREAS, said water, storm and sanitary sewer maintenance and/or sewerage treatment rates shall be applied as follows:

Single Family	Front footage x maintenance rate
Condominiums	Average front footage for the community x 0.87 x sewer maintenance rate
Apartments	Per settlement formula per Common Pleas Case #245631
Commercial	Front footage x maintenance rate x 1.15
Industrial	Front footage x maintenance rate x 1.15

WHEREAS, it is necessary that this Resolution become immediately effective in order that critical services provided by Cuyahoga County can continue and to provide for the usual, daily operation of a County entity.

NOW, THEREFORE, BE IT RESOLVED BY THE COUNTY COUNCIL OF CUYAHOGA COUNTY, OHIO:

SECTION 1. That in order to provide funds with which to maintain and operate water lines and sewerage systems in County Sewer District Nos. 1, 1A, 2, 3, 5, 8, 9, 13, 14, 18, 20, 21, 22 and 24 for Fiscal 2024, the following rates shall be charged to the actual and/or potential users of such sewerage system:

**Sewer Maintenance Rate
(Per Front Foot)**

2023

Sewer Area No. 1

Brooklyn	
Sanitary Sewer	\$ 2.20
Storm Sewer	\$.40
Linndale - All Sewers	\$ 2.50
Parma Heights	
Sanitary Sewer	\$ 1.20
Storm Sewer	\$ 1.25
Water Transmission Lines	\$ 0.05

Sewer Area No. 1A

Parma	
Sanitary Sewers	\$ 1.75
Storm Sewers	\$ 0.40

Sewer Area No. 2

Brooklyn Heights	
Sanitary Sewers	\$ 1.50
Storm Sewers	\$ 0.25
Seven Hills - Sanitary Sewers	\$ 1.00 (A)

Sewer Area No. 3

Beachwood	
Sanitary Sewers	\$ 0.75
Storm Sewers	\$ 0.75
Gates Mills - Sanitary Sewers	\$ 10.00
Highland Heights	
Sanitary Sewers	\$ 1.00
Storm Sewers	\$ 1.50
Lyndhurst - Sanitary Sewers	\$ 1.00
Mayfield Heights	
Sanitary Sewers	\$ 2.50
Storm Sewers	\$ 0.00

Mayfield Village - Sanitary Sewers	\$ 2.00
Pepper Pike - Sanitary Sewers	\$ 2.50
	\$ 200.00 (B)
Richmond Heights	
Sanitary Sewers	\$ 2.00
Storm Sewers	\$ 0.70
South Euclid - Sanitary Sewers	\$ 1.00 (C)

Sewer Area No. 5

Beachwood	
Sanitary Sewers	\$ 0.75
Storm Sewers	\$ 0.75
Bedford Heights - Sanitary Sewers	\$ 1.95
Highland Hills - Storm Only	\$ 2.50
North Randall	
Sanitary Sewers	\$ 0.75
Storm Sewers	\$ 1.75
Orange Village - Sanitary Sewers	\$ 3.00
Warrensville Heights	
Sanitary Sewers	\$1.25
Storm Sewers	\$1.25

Sewer Area No. 8

Middleburg Heights	
Sanitary Sewer	\$ 2.00
Storm Sewer	\$ 0.50
Water Transmission Lines	\$ 0.20

Sewer Area No. 9

Garfield Heights	
Sanitary Sewers	\$ 2.20
Storm Sewers	\$ 0.30
Maple Heights	
Sanitary Sewers	\$ 2.25
Storm Sewers	\$ 0.95
Water Transmission Lines	\$ 0.10

Sewer Area No. 13

Brecksville	
Sanitary Sewers	\$ 2.50
Storm Sewers	\$ 2.10
Broadview Heights	
Sanitary Sewers	\$ 1.50

Sewer Area No. 14

Olmsted Township	
------------------	--

Sanitary Sewers	\$ 3.50
Storm Sewers	\$ 0.47
Sewer Area No. 18	
Oakwood	
Sanitary Sewers	\$1.10
Storm Sewers	\$0.40
Sewer Area No. 20	
Bedford - Sanitary Sewers	\$ 1.60
Walton Hills - Sanitary Sewers	\$ 1.60 (D)
	\$ 150.00 (E)
Sewer Area No. 21	
Woodmere	
Sanitary Sewers	\$ 2.25
	\$ 225.00 (F)
	\$ 150.00 (F)
Storm Sewers	\$ 0.40
Water Transmission Lines	\$ 0.10
Sewer Area No. 22	
Newburgh Heights - All Sewers	\$ 6.20
Sewer Area No. 24	
East Cleveland - All Sewers	\$ 3.00

- (A) Rate Applies to properties served by County Improvement No. 231.
- (B) Flat Rate: \$200.00 per year to residential parcels tributary to Creekside, (ten years - beginning 1/1/2016). Commercial charge based on water consumption.
- (C) Rate Applies to portion of South Euclid tributary to County Improvement Nos. 3-A-1 and 3-A-2 only.
- (D) Rate Applies to commercial/industrial parcels only
- (E) Flat Rate: \$150.00 charge for a residential parcel served by sanitary sewers.
- (F) Flat Rate: \$225.00 charge for each improved parcel for 2024.
\$150.00 charge for each unimproved parcel for 2024.

Any charges that are not paid shall be certified to the County Fiscal Officer, as provided by law, for collection.

First Reading/Referred to Committee: July 18, 2023
Committee(s) Assigned: Public Works, Procurement & Contracting

Journal _____
_____,20____

DPW 2024, Authorization to Prepare (Fixing) 2024 Sewer Maintenance Rates for Municipalities (part 1 of 2)

Scope of Work Summary

Department of Public Works requesting authorization to prepare maintenance assessments for County sewer Area Numbers 1, 1A, 2, 3, 5, 8, 9, 13, 14, 18, 20, 21, 22, 24 for Fiscal 2024. The County of Cuyahoga approves rates for the Sanitary Engineering Division because the County has contractual obligations with communities to operate and maintain sewerage systems including sanitary sewers, storm sewers, wastewater treatment plants and pumping stations. There is no cost associated with this specific agreement.

The primary goal is to collect all operational expenditures for revenues collected from users of the sewerage system (level-one financing). Each sewer area differs in population size, lineal feet sewers and number of wastewater treatment plants and/or pumping stations that must be maintained. This results in cost variations requiring different rates between and sometimes within areas. Secondly, sewer area accounts should always reflect a reserve balance to respond to unplanned repairs and/or replacement of sewerage systems. Area/community balances will be considered capital funds that can be expended on unplanned projects and/or condition of the sewer system and attempts to repair/replace systems where necessary, (planned capital projects) and within funds available for this (level-three financing). It is the intent of the department to continue financing its operation at all three (3) levels and to continue its program in accordance with contractual obligations and effective engineering practices.

The rates are in accordance with the Ohio Revised Code Chapter 6117.02 stating the County may levy an assessment to pay the cost and expense of the maintenance and operation of such sewerage improvements, including disposal of sewage.

Contractor and Project Information

The municipalities are divided into Sewer Areas, which can be found on attachment. The Sewer Areas are within the following County Districts: 1, 2, 4, 5, 6, 8, 9, 10, 11.

Project Status and Planning

The rate schedule is updated annually. The rates must be passed by Council on or before September 11, 2023, per Ohio Revised Code 6117.33 which provides that assessments for such rates must be certified on or before the second Monday in September.

Funding

There is no cost associated with this.



Department of Public Works/ Sanitary Engineering Division

County of Cuyahoga Sewer Area Rates for 2024

The rates are varied based upon Cuyahoga County division into Sewer Areas. The Ohio Revised Code requires that accounts be established for each sewer area and communities not part of a sewer area.

The proposed rates were determined as follows:

- Estimate costs for engineering, sewer inspection, treatment plants, pumping stations, lab analysis, and sewer maintenance programs **(Level one financing)**
- Maintain sufficient fund balances in the Sewer Area Accounts for emergency repairs or replacement of sanitary sewers; pumping stations, wastewater treatment plants and current/future capital debt **(Level two financing)**
- Provide capital funding (\$4-5 million) for planned/potential projects **(Level three financing)**

The rates shall be applied as follows:

Single Family	Front footage x maintenance rate
Condominiums	Average front footage for the community x 0.87 x sewer maintenance rate
Apartments	Per settlement formula per Common Pleas Case # 245631
Commercial	Front footage x maintenance rate x 1.15
Industrial	Front footage x maintenance rate x 1.15

In order to provide funds with which to maintain and operate Sewerage improvements in areas designated from January 1, 2024 forward, the following rates shall be charged to the actual and/or potential users of such sewerage system:

**2024 Sewer Maintenance Rate
(Per Front Foot)**

Sewer Area No. 1

Brooklyn	
Sanitary Sewer	\$ 2.20
Storm Sewer	\$.40
Linndale – All Sewers	\$ 2.50
Parma Heights	
Sanitary Sewer	\$ 1.20
Storm Sewer	\$ 1.25
Water Transmission Lines	\$ 0.05

Sewer Area No. 1A

Parma	
Sanitary Sewers	\$ 1.75
Storm Sewers	\$ 0.40

Sewer Area No. 2

Brooklyn Heights	
Sanitary Sewers	\$ 1.50
Storm Sewers	\$ 0.25
Seven Hills – Sanitary Sewers	\$ 1.00 (A)

Sewer Area No. 3

Beachwood	
Sanitary Sewers	\$ 0.75
Storm Sewers	\$ 0.75
Gates Mills – Sanitary Sewers	\$10.00
Highland Heights	
Sanitary Sewers	\$ 1.00
Storm Sewers	\$ 1.50
Lyndhurst – Sanitary Sewers	\$ 1.00
Mayfield Heights – Sanitary Sewers	\$ 2.50
Storm Sewers	\$ 0.00
Mayfield Village – Sanitary Sewers	\$ 2.00
Pepper Pike – Sanitary Sewers	\$ 2.50
	\$ 200.00 (B)
Richmond Heights	
Sanitary Sewers	\$ 2.00
Storm Sewers	\$ 0.70
South Euclid – Sanitary Sewers	\$ 1.00 (C)

**2024 Sewer Maintenance Rate
(Per Front Foot)**

Sewer Area No. 5

Beachwood – Sanitary Sewers	\$ 0.75
Storm Sewers	\$ 0.75
Bedford Heights – Sanitary Sewers	\$ 1.95
Highland Hills - Storm Only	\$ 2.50
North Randall	
Sanitary Sewers	\$ 0.75
Storm Sewers	\$ 1.75
Orange Village – Sanitary Sewers	\$ 3.00
Warrensville Heights	
Sanitary Sewers	\$ 1.25
Storm Sewers	\$ 1.25

Sewer Area No. 8

Middleburg Heights	
Sanitary Sewers	\$ 2.00
Storm Sewers	\$ 0.50
Water Transmission Lines	\$ 0.20

Sewer Area No. 9

Garfield Heights	
Sanitary Sewers	\$ 2.70
Storm Sewers	\$ 0.30
Maple Heights	
Sanitary Sewers	\$ 2.25
Storm Sewers	\$ 0.95
Water Transmission Lines	\$ 0.10

Sewer Area No. 13

Brecksville	
Sanitary Sewers	\$ 2.50
Storm Sewers	\$ 2.10
Broadview Heights	
Sanitary Sewers	\$ 1.50

Sewer Area No. 14

Olmsted Township	
Sanitary Sewers	\$ 3.50
Storm Sewers	\$ 0.47

Sewer Area No. 18

Oakwood – Sanitary Sewers	\$ 1.10
Storm Sewers	\$ 0.40

**2024 Sewer Maintenance Rate
(Per Front Foot)**

Sewer Area No. 20

Bedford – Sanitary Sewers	\$ 1.60
Walton Hills – Sanitary Sewers	\$ 1.60 (D)
	\$150.00 (E)

Sewer Area No. 21

Woodmere - Sanitary Sewers	\$ 2.25
	\$ 225.00 (F)
	\$ 150.00 (F)
Storm Sewers	\$ 0.40
Water Trans. Lines	\$ 0.10

Sewer Area No. 22

Newburgh Heights – All Sewers	\$ 6.20
-------------------------------	---------

Sewer Area No. 24

East Cleveland – All Sewers	\$ 3.00
-----------------------------	---------

- (A) Rate Applies to properties served by County Improvement No. 231.
- (B) Flat Rate: \$ 200.00 per year to residential parcels tributary to Creekside, (ten years - beginning 01/2016). Commercial charge based on water consumption.
- (C) Rate Applies to portion of South Euclid tributary to County Improvement Nos. 3-A-1 and 3-A-2 only.
- (D) Rate applies to commercial/industrial area only
- (E) Flat Rate: \$ 150.00 charge per residential parcel served by sewers
- (F) Flat Rate: \$ 225.00 charge for each improved parcel for 2024
\$ 150.00 charge for each unimproved lot for 2024

Any charges that are not paid shall be certified to the County Fiscal Officer, as provided by law, for collection.

The Clerk of Council is hereby, instructed to transmit a copy of this resolution to the County Fiscal Officer and one copy to the Department of Public Works/Sanitary Engineer.

County Council of Cuyahoga County, Ohio

Resolution No. R2023-0212

Sponsored by: County Executive Ronayne/Department of Public Works	A Resolution approving and confirming the 2024 water, storm and sanitary sewer maintenance and/or sewerage treatment assessments for County Sewer District Nos. 1, 1A, 2, 3, 5, 8, 9, 13, 14, 18, 20, 21, 22 and 24, in accordance with Ohio Revised Code Section 6117.02; and declaring the necessity that this Resolution become immediately effective.
--	--

WHEREAS, the County Sanitary Engineer has prepared and presented to the County Council for the County of Cuyahoga, Ohio the 2024 water, storm and sanitary sewer maintenance and/or sewerage treatment assessments for County Sewer District Nos. 1, 1A, 2, 3, 5, 8, 9, 13, 14, 18, 20, 21, 22 and 24; and

WHEREAS, funds are necessary to pay for the operation and maintenance of water lines, sewerage systems, including storm sewers, sanitary sewers, wastewater treatment plants, and pumping stations for said Districts for Fiscal 2024; and

WHEREAS, the primary goal is to collect all operational expenditures from revenues collected from users of the water lines and sewerage systems; and

WHEREAS, in accordance with the Ohio Revised Code Section 6117.02, the County may levy an assessment to pay the cost and expense of the maintenance and operation of such improvements, including the disposal of sewage; and

WHEREAS, it is necessary that this Resolution become immediately effective in order that critical services provided by Cuyahoga County can continue and to provide for the usual, daily operation of a County entity.

NOW, THEREFORE, BE IT RESOLVED BY THE COUNTY COUNCIL OF CUYAHOGA COUNTY, OHIO:

SECTION 1. That the water, storm and sanitary sewer maintenance and/or sewerage treatment assessments for County Sewer District Nos. 1, 1A, 2, 3, 5, 8, 9, 13, 14, 18, 20, 21, 22 and 24, as prepared and filed with the Council by the County Sanitary Engineer be, and the same are, hereby approved and confirmed and said assessments are hereby ordered recorded in the original assessment records of the County of Cuyahoga, Ohio for the year 2024, to which reference is hereby made a part hereof, as fully and completely as though set forth at length and rewritten herein.

SECTION 2. That there be, and hereby is, levied and assessed upon the several lots and parcels of land listed and described in said report the amount set forth to be assessed by the County of Cuyahoga, Ohio, through the Department of Public Works/County Sanitary Engineer, upon each of said lots and parcels of land.

SECTION 3. That the said assessments so made, approved and confirmed, are hereby certified to the County Fiscal Officer for collection.

SECTION 4. That the installments of such assessments, when collected, shall be placed to the credit of the Department of Public Works/County Sanitary Engineer's fund to be used for the purposes set forth in the Resolution directing the Department to prepare such assessments.

SECTION 5. That the Clerk of Council be, and she is hereby, instructed to transmit a copy of this Resolution to the County Fiscal Officer and one copy to the Department of Public Works/County Sanitary Engineer.

SECTION 6. It is necessary that this Resolution become immediately effective to comply with the Ohio Revised Code, Section 6117.33, which provides that assessments for such rates must be certified on or before the second Monday in September, that being September 9, 2019. Provided that this Resolution receives the affirmative vote of at least eight members of Council, it shall take effect and be in force immediately upon the earliest occurrence of any of the following: (1) its approval by the County Executive through signature, (2) the expiration of the time during which it may be disapproved by the County Executive under Section 3.10(6) of the Cuyahoga County Charter, or (3) its passage by at least eight members of Council after disapproval pursuant to Section 3.10(7) of the Cuyahoga County Charter. Otherwise, it shall take effect and be in force from and after the earliest period allowed by law.

SECTION 7. It is found and determined that all formal actions of this Council relating to the adoption of this Resolution were adopted in an open meeting of the Council, and that all deliberations of this Council and any of its committees that resulted in such formal action were in meetings open to the public, in compliance with all legal requirements, including Section 121.22 of the Ohio Revised Code.

On a motion by _____, seconded by _____, the foregoing Resolution was duly adopted.

Yeas:

Nays:

County Council President

Date

County Executive

Date

Clerk of Council

Date

First Reading/Referred to Committee: July 18, 2023

Committee(s) Assigned: Public Works, Procurement & Contracting

Journal _____
_____,20____

DPW, REQUESTING Approval & Confirmation of 2024 SEWER MAINTENANCE RATES FOR MUNICIPALITIES
(part 2 of 2)

Scope of Work Summary

Department of Public Works requesting approval and confirmation to prepare maintenance assessments for County Sewer Area Numbers 1, 1A, 2, 3, 5, 8, 9, 13, 14, 18, 20, 21, 22, 24 for Fiscal 2024. The County of Cuyahoga approves rates for the Sanitary Engineering Division because the County has contractual obligations with communities to operate and maintain sewerage systems including sanitary sewers, storm sewers, wastewater treatment plants, and pumping stations. There is no cost associated with this specific agreement.

The primary goal is to collect all operational expenditures for revenues collected from users of the sewerage system (level-one financing). Each sewer area differs in population size, lineal feet sewers and number of wastewater treatment plants and/or pumping stations that must be maintained. This results in cost variations requiring different rates between and sometimes within areas. Secondly, sewer area accounts should always reflect a reserve balance to respond to unplanned repairs and/or replacement of sewerage systems. Area/community balances will be considered capital funds that can be expended on unplanned projects and/or pay long-term capital debt (level-two financing). Lastly the Sanitary Engineering Division routinely evaluates the condition of the sewer system and attempts to repair/replace systems where necessary, (planned capital projects) and within funds available for this (level-three financing). It is the intent of the department to continue financing its operation at all three (3) levels and to continue its program in accordance with contractual obligations and effective engineering practices.

The rates are in accordance with the Ohio Revised Code Chapter 6117.02 stating the County may levy an assessment to pay the cost and expense of the maintenance and operation of such sewerage improvements, including the disposal of sewage.

CONTRACTOR AND PROJECT INFORMATION

The municipalities are divided into Sewer Areas, which can be found in the attachment. The Sewer Areas are within the following County Districts: 1, 2, 3, 4, 5, 6, 8, 9, 10, 11

PROJECT STATUS AND PLANNING

The rate schedule is updated annually. The rates must be passed by Council on or before September 11, 2023, per Ohio Revised Code 6117.33 which provides that assessments for such rates must be certified on or before the second Monday in September.

FUNDING

There is no cost associated with this.



Department of Public Works/ Sanitary Engineering Division

County of Cuyahoga Sewer Area Rates for 2024

The rates are varied based upon Cuyahoga County division into Sewer Areas. The Ohio Revised Code requires that accounts be established for each sewer area and communities not part of a sewer area.

The proposed rates were determined as follows:

- Estimate costs for engineering, sewer inspection, treatment plants, pumping stations, lab analysis, and sewer maintenance programs **(Level one financing)**
- Maintain sufficient fund balances in the Sewer Area Accounts for emergency repairs or replacement of sanitary sewers; pumping stations, wastewater treatment plants and current/future capital debt **(Level two financing)**
- Provide capital funding (\$4-5 million) for planned/potential projects **(Level three financing)**

The rates shall be applied as follows:

Single Family	Front footage x maintenance rate
Condominiums	Average front footage for the community x 0.87 x sewer maintenance rate
Apartments	Per settlement formula per Common Pleas Case # 245631
Commercial	Front footage x maintenance rate x 1.15
Industrial	Front footage x maintenance rate x 1.15

In order to provide funds with which to maintain and operate Sewerage improvements in areas designated from January 1, 2024 forward, the following rates shall be charged to the actual and/or potential users of such sewerage system:

**2024 Sewer Maintenance Rate
(Per Front Foot)**

Sewer Area No. 1

Brooklyn	
Sanitary Sewer	\$ 2.20
Storm Sewer	\$.40
Linndale – All Sewers	\$ 2.50
Parma Heights	
Sanitary Sewer	\$ 1.20
Storm Sewer	\$ 1.25
Water Transmission Lines	\$ 0.05

Sewer Area No. 1A

Parma	
Sanitary Sewers	\$ 1.75
Storm Sewers	\$ 0.40

Sewer Area No. 2

Brooklyn Heights	
Sanitary Sewers	\$ 1.50
Storm Sewers	\$ 0.25
Seven Hills – Sanitary Sewers	\$ 1.00 (A)

Sewer Area No. 3

Beachwood	
Sanitary Sewers	\$ 0.75
Storm Sewers	\$ 0.75
Gates Mills – Sanitary Sewers	\$10.00
Highland Heights	
Sanitary Sewers	\$ 1.00
Storm Sewers	\$ 1.50
Lyndhurst – Sanitary Sewers	\$ 1.00
Mayfield Heights – Sanitary Sewers	\$ 2.50
Storm Sewers	\$ 0.00
Mayfield Village – Sanitary Sewers	\$ 2.00
Pepper Pike – Sanitary Sewers	\$ 2.50
	\$ 200.00 (B)
Richmond Heights	
Sanitary Sewers	\$ 2.00
Storm Sewers	\$ 0.70
South Euclid – Sanitary Sewers	\$ 1.00 (C)

**2024 Sewer Maintenance Rate
(Per Front Foot)**

Sewer Area No. 5

Beachwood – Sanitary Sewers	\$ 0.75
Storm Sewers	\$ 0.75
Bedford Heights – Sanitary Sewers	\$ 1.95
Highland Hills - Storm Only	\$ 2.50
North Randall	
Sanitary Sewers	\$ 0.75
Storm Sewers	\$ 1.75
Orange Village – Sanitary Sewers	\$ 3.00
Warrensville Heights	
Sanitary Sewers	\$ 1.25
Storm Sewers	\$ 1.25

Sewer Area No. 8

Middleburg Heights	
Sanitary Sewers	\$ 2.00
Storm Sewers	\$ 0.50
Water Transmission Lines	\$ 0.20

Sewer Area No. 9

Garfield Heights	
Sanitary Sewers	\$ 2.70
Storm Sewers	\$ 0.30
Maple Heights	
Sanitary Sewers	\$ 2.25
Storm Sewers	\$ 0.95
Water Transmission Lines	\$ 0.10

Sewer Area No. 13

Brecksville	
Sanitary Sewers	\$ 2.50
Storm Sewers	\$ 2.10
Broadview Heights	
Sanitary Sewers	\$ 1.50

Sewer Area No. 14

Olmsted Township	
Sanitary Sewers	\$ 3.50
Storm Sewers	\$ 0.47

Sewer Area No. 18

Oakwood – Sanitary Sewers	\$ 1.10
Storm Sewers	\$ 0.40

**2024 Sewer Maintenance Rate
(Per Front Foot)**

Sewer Area No. 20

Bedford – Sanitary Sewers	\$ 1.60
Walton Hills – Sanitary Sewers	\$ 1.60 (D)
	\$150.00 (E)

Sewer Area No. 21

Woodmere - Sanitary Sewers	\$ 2.25
	\$ 225.00 (F)
	\$ 150.00 (F)
Storm Sewers	\$ 0.40
Water Trans. Lines	\$ 0.10

Sewer Area No. 22

Newburgh Heights – All Sewers	\$ 6.20
-------------------------------	---------

Sewer Area No. 24

East Cleveland – All Sewers	\$ 3.00
-----------------------------	---------

- (A) Rate Applies to properties served by County Improvement No. 231.
- (B) Flat Rate: \$ 200.00 per year to residential parcels tributary to Creekside, (ten years - beginning 01/2016). Commercial charge based on water consumption.
- (C) Rate Applies to portion of South Euclid tributary to County Improvement Nos. 3-A-1 and 3-A-2 only.
- (D) Rate applies to commercial/industrial area only
- (E) Flat Rate: \$ 150.00 charge per residential parcel served by sewers
- (F) Flat Rate: \$ 225.00 charge for each improved parcel for 2024
\$ 150.00 charge for each unimproved lot for 2024

Any charges that are not paid shall be certified to the County Fiscal Officer, as provided by law, for collection.

The Clerk of Council is hereby, instructed to transmit a copy of this resolution to the County Fiscal Officer and one copy to the Department of Public Works/Sanitary Engineer.

County Council of Cuyahoga County, Ohio

Resolution No. R2023-0213

Sponsored by: County Executive Ronayne/Department of Public Works	A Resolution making an award on RQ12725 with Specialized Construction, Incorporated in the amount not-to-exceed \$1,082,130.86 for asphalt resurface preservation, crack sealing and striping for 2023 Countywide Preventative Maintenance Program; authorizing the County Executive to execute Contract No. 3582 and all other documents consistent with said award and this Resolution; and declaring the necessity that this Resolution become immediately effective.
--	---

WHEREAS, the County Executive/Department of Public Works recommends an award on RQ12725 with Specialized Construction, Incorporated in the amount not-to-exceed \$1,082,130.86 for asphalt resurface preservation, crack sealing and striping for 2023 Countywide Preventative Maintenance Program; and

WHEREAS, the primary goals of this project include asphalt surface preservation, crack sealing and striping of various pavements; and

WHEREAS, the project is funded 100% by Road and Bridge Fund; and

WHEREAS, it is necessary that this Resolution become immediately effective in order that critical services provided by Cuyahoga County can continue and to provide for the usual, daily operation of a County entity.

NOW, THEREFORE, BE IT RESOLVED BY THE COUNTY COUNCIL OF CUYAHOGA COUNTY, OHIO:

SECTION 1. That the Cuyahoga County Council hereby makes an award on RQ12725 with Specialized Construction, Incorporated in the amount not-to-exceed \$1,082,130.86 for asphalt resurface preservation, crack sealing and striping for 2023 Countywide Preventative Maintenance Program.

SECTION 2. That the County Executive is authorized to execute Contract No. 3582 and all other documents consistent with said award and this Resolution.

SECTION 3. It is necessary that this Resolution become immediately effective for the usual daily operation of the County; the preservation of public peace, health, or safety in the County; and any additional reasons set forth in the preamble. Provided that this Resolution receives the affirmative vote of at least eight members of Council,

Department of Public Works 2023 Countywide preventative Maintenance Crack Sealing and Striping in Various Cuyahoga Counties, Ohio

Scope of Work Summary

Department of Public Works is requesting approval of a contract with Specialized Construction Inc. For the anticipated cost of \$1,082,130.86.

The work within the limits of this project shall include the asphalt surface preservation, crack sealing and striping of various pavements as stipulated in the Special Provisions, Supplemental Specifications Proposal Notes and elsewhere in the bid package documents for the following roads.

CRACK SEALING AND STRIPING –

BAGLEY ROAD – Pearl Road to West 130th Street in Middleburg Heights

W. 130TH STREET – Bagley Rd to Snow Rd in Brook Park / Parma / Parma Hts. / Middleburg Hts.

EAST 131ST STREET – Forestdale Drive to Miles Avenue in Garfield Heights / Cleveland

WARRENSVILLE CENTER RD – Meadowgate Blvd to the Maple Hts. NCL in Bedford/Maple Hts.

CEDAR ROAD – Green Road to I-271 in Beachwood / South Euclid / Lyndhurst / University Heights

Section 2 Page 2 of 8

ASPHALT SURFACE PRESERVATION –

ROYALTON ROAD – W. 130TH Street to York Road in North Royalton

RIDGE ROAD – Memphis Avenue to Denison Avenue in Brooklyn / Cleveland

EAST 116TH STREET – Miles Avenue to Union Avenue in Cleveland

BRAINARD ROAD – Falkirk Road to Wilson Mills Road in Highland Heights / Lyndhurst

CEDAR ROAD – SOM Center Road to Chagrin River Road in Gates Mills / Hunting Valley

WOLF ROAD – Sutcliffe Drive to Clague Road in Bay Village

LEE BOULEVARD – Euclid Avenue to Forest Hills Boulevard in East Cleveland

SOUTH GREEN ROAD – Mayfield Road to Monticello Boulevard in South Euclid

UNION STREET – Broadway Avenue (N.) to Broadway Avenue (S.) in Bedford

YORK ROAD – Pleasant Valley Road to Pearl Road in Parma / Parma Heights

E. SPRAGUE ROAD – Broadview Road to Seven Hills ECL in Seven Hills / Broadview Heights

Anticipated dates are to 8/14/2023-10/27/2023.

The primary goals of the project are: see above.

The project is not mandated. This is to be performed in Independence and Valley View.

Procurement

The procurement method for this project was RFB. The total value of the RFB is \$1,082,130.86. The RFB was closed on 6/21/2023. There is an SBE or DBE participation/goal of SBE-Set Aside, MBE 6%, and WBE 2%. There were 1 bid pulled from OPD, 1 bid submitted for review, 1 bid approved. For this project the engineer's estimate was \$1,033,238.00 and this was increase by 4.6%.

Contractor and Project Information

Specialized Construction Inc.

711 Harvard Avenue

Cuyahoga Heights, OH 44105

Council District (8)

The president for the contractor/vendor is Brian Hall.

The address or location of the project is: Various Location in Cuyahoga County.
The project is in Council District (all)

Project Status and Planning

The project is new to the County.

Funding

The project is funded (100% by County funds. Road and Bridge \$7.50 Fund). The schedule of payment is by invoice.

Department of Purchasing – Required Documents Checklist

Upload as “word” document in Infor

Infor/Lawson RQ#:	12725
Infor/Lawson PO # Code (if applicable):	
Event #	
CM Contract#	3582

	Department	Clerk of the Board
Briefing Memo	WB	

Late Submittal Required:	Yes <input type="checkbox"/>	No <input checked="" type="checkbox"/>
Why is the contract being submitted late?		
What is being done to prevent this from reoccurring?		

TAC or CTO Required or authorized IT Standard	Yes <input type="checkbox"/>	No <input checked="" type="checkbox"/>
---	------------------------------	--

FULL AND OPEN COMPETITION Construction Projects – Road & Bridge Reviewed by Purchasing		
	Department initials	Purchasing
Notice of Intent to Award <i>(sent to all responding vendors)</i>	WB	Ok-6/28/2023 lz
Bid Specification Packet <i>(includes Legal Notice to Bidders)</i>	WB	Ok-6/28/2023 lz
Final DEI Goal Setting Worksheet	WB	Ok-6/28/2023 lz
Diversity Documents – <i>if required (goal set)</i>	WB	Ok-6/28/2023 lz
Award Letter <i>(sent to awarded vendor)</i>	WB	Ok-6/28/2023 lz
Vendor’s Confidential Financial Statement – <i>if RFB requested</i>	N/A	N/A
Non-Collusion Affidavit	WB	Ok-6/28/2023 lz
Public Works Bid Results SEE Tab Sheet	WB	Ok-6/28/2023 lz
Tabulation Sheet	WB	Ok-6/28/2023 lz
Prevailing Wage Public Improvement Agreement	WB	Ok-6/28/2023 lz
Sales and Use Tax Construction Contract Exemption Form, <i>if applicable</i>	WB	Ok-6/28/2023 lz
Worktype Worksheets, <i>if applicable</i>	WB	Ok-6/28/2023 lz
SBE Worktype Worksheets, <i>if applicable</i>	WB	Ok-6/28/2023 lz
Drug Free Workplace, <i>if applicable</i>	WB	Ok-6/28/2023 lz
Project of Similar Complexity, <i>if applicable</i>	WB	Ok-6/28/2023 lz
EEOC (Equal Employment Opportunity Commission), <i>if applicable</i>	N/A	N/A
Prevailing Wage Determination Cover Letter (with Prevailing Wage Rate sheets)	SSE WEB	Ok-6/28/2023 lz
Other, <i>per Section 3 “Required Bid Documents”</i>	N/A	N/A
IG# 20-0170-REG 31DEC2024	WB	Specialized Construction Inc. 20-0170- REG 31DEC2024

Department of Purchasing – Required Documents Checklist

Upload as “word” document in Infor

Debarment/Suspension Verified	Date:	6/28/23	WB	Ok-within 60 days
Auditor’s Finding	Date:	6/28/23	WB	Ok-within 60 days
Vendor’s Submission (<i>Form of Proposal</i>)			WB	ok
Independent Contractor (I.C.) Requirement	Date:	6/27/23	WB	Ok-dated within 1 yr
Contract Evaluation – <i>if required</i>			N/A	N/A
TAC/CTO Approval or IT Standards (attach and identify relevant page #s), <i>if required</i> .			N/A	N/A
Checklist Verification			WB	Ok-6/28/2023 lz

Other documentation may be required depending upon your specific item

Glossary of Terms at: <https://intranet.cuyahoga.cc/policies-procedures/procurement-information>

Reviewed by Law	
	Department initials
Agreement/Contract and Exhibits	WB
Bid Guarantee & Contract Bond	WB
Matrix Law Screen shot	WB
COI	WB
Workers’ Compensation Insurance	WB
Railroad Insurance – <i>if required</i>	N/A

Accounting Units

Time Period	Accounting Unit	Account Number	Sub Account	Dollar Amount
8/14/2023 – 10/27/2023	PW270205	73300		\$1,082,130.86
			TOTAL	\$1,082,130.86

Purchasing Use Only:

Prior Resolutions:	N/A
CM#:	3582
Vendor Name:	Specialized Construction Inc. 20-0170-REG 31DEC2024
ftp:	8/14/2023-10/27/2023
Amount:	\$1,082,130.86
History/CE:	OK
EL:	OK
Procurement Notes:	BUYER REVIEW COMPLETED

Department of Purchasing – Required Documents Checklist

Upload as “word” document in Infor

Purchasing Buyer’s initials and date of approval	LZ 6.28.2023
--	--------------



Department of Purchasing Tabulation Sheet

REQUISITION NUMBER: 12725 Event: 4432	TYPE: (RFB/RFP/RFQ): RFB	ESTIMATE: \$1,033,238.00 10% = \$1,136,561.80
CONTRACT PERIOD:	RFB/RFP/RFQ DUE DATE: June 21, 2023	NUMBER OF RESPONSES (issued/submitted): 4/1
REQUESTING DEPARTMENT: Public Works	COMMODITY DESCRIPTION: 2023 Countywide Preventative Maintenance Program Asphalt Surface Preservation, Crack Sealing and Striping	
DIVERSITY GOAL/SBE SET ASIDE	DIVERSITY GOAL/MBE 6%	DIVERSITY GOAL/WBE 2%
Does CCBB Apply: <input type="checkbox"/> Yes <input checked="" type="checkbox"/> No-The low bidder is in Cuyahoga County, JW 6/23/2023	CCBB: Low Non-CCBB Bid\$: \$0	Add 2%, Total is: \$0
Does CCBEIP Apply: <input type="checkbox"/> Yes <input checked="" type="checkbox"/> No-The low bidder is certified as an "Inclusive Bidder" in the CCBEIP, JW 6/23/2023	CCBEIP: Low Non-CCBEIP Bid \$: \$0	Add 2%, Total is: \$0
*PRICE PREFERENCE LOWEST BID REC'D \$1,082,130.86	RANGE OF LOWEST BID REC'D \$ 1,000,000.01-\$3,000,000	Minus \$, =
PRICE PREF % & \$ LIMIT: (8%) \$86,570.47 (Max \$210,000)	MAX SBE/MBE/WBE PRICE PREF \$ 1,168,701.33	DOES PRICE PREFERENCE APPLY? <input type="checkbox"/> Yes <input type="checkbox"/> No

Bidder's / Vendors Name and Address	Bid Bond / Check	Actual Bid Amount (enter "N/A" if RFP or RFQ)	Buyer Administrative Review: Buyer Initials	Price Preference	CCBB / CCBEIP Registered	Diversity Program Review: SBE / MBE / WBE	Dept. Tech. Review	Award: (Y/N)
1 Specialized Construction Inc 711 Harvard Ave Cuyahoga Hts OH 44105	100% Nationwide Mutual Insurance Company	\$1,082,130.86	Compliant: <input checked="" type="checkbox"/> Yes IG Registration Complete: <input checked="" type="checkbox"/> Yes IG Number: 20-0170-REG NCA: <input checked="" type="checkbox"/> Yes PH: <input checked="" type="checkbox"/> Yes CCBB: <input checked="" type="checkbox"/> Yes Response: <input checked="" type="checkbox"/> Yes CCBEIP: <input checked="" type="checkbox"/> Yes Response: <input checked="" type="checkbox"/> Yes Proposal Form: <input checked="" type="checkbox"/> Yes	<input type="checkbox"/> Yes <input type="checkbox"/> No	CCBB <input checked="" type="checkbox"/> Yes <input type="checkbox"/> No CCBEIP <input checked="" type="checkbox"/> Yes <input type="checkbox"/> No	Subcontractor Name(s): (MAA) Specialized Construction, Inc. Prime SBE MBE 20% (Set Aside) (FAA) Cook Paving & Construction Co. Inc. SBE MBE WBE 6.01% (FW) Timeline Photography, LLC SBE WBE 0.28% (FW) Trafftech, Inc. SBE WBE 12.58% SBE/MBE/WBE Prime: (Y/N) <input checked="" type="checkbox"/> Yes <input checked="" type="checkbox"/> SBE <input checked="" type="checkbox"/> MBE <input type="checkbox"/> WBE <input type="checkbox"/> No Total % SBE: Prime (20%) MBE: 6.01% WBE: 12.86% SBE/MBE/WBE Comply: (Y/N) <input checked="" type="checkbox"/> Yes LL 6/26/2023 <input type="checkbox"/> No SBE/MBE/WBE Comments and Initials: Pavement Technology is not Certified. No waiver was requested. 6/22/2023 CF Pavement Technology is not Cuyahoga County Certified, no waiver requested, goals met,	DPW Recommend Award, Lowest and Best Bid. WB 6/26/23	<input checked="" type="checkbox"/> Yes <input type="checkbox"/> No

Transaction ID:

Bidder's / Vendors Name and Address	Bid Bond / Check	Actual Bid Amount (enter "N/A" if RFP or RFQ)	Buyer Administrative Review: Buyer Initials	Price Preference	CCBB / CCBEIP Registered	Diversity Program Review: SBE / MBE / WBE	Dept. Tech. Review	Award: (Y/N)
			Prime Worksheets : <input checked="" type="checkbox"/> Yes Drug-Free: <input checked="" type="checkbox"/> Yes Bid Bond: <input checked="" type="checkbox"/> Yes OPD Buyer Initials: AJ 6/22/2023			JW 6/23/2023 LL 6/26/2023 [Redacted] [Redacted]		

County Council of Cuyahoga County, Ohio

Resolution No. R2023-0214

<p>Sponsored by: County Executive Ronayne/Department of Public Works/ Division of County Engineer</p>	<p>A Resolution making awards on RQ12381 with various engineering firms in the total amount not-to-exceed \$1,350,000.00 for general engineering services, commencing upon contract signature of all parties for a period of three (3) years; authorizing the County Executive to execute Contract Nos. 3585, 3586 & 3854 and all other documents consistent with said awards and this Resolution; and declaring the necessity that this Resolution become immediately effective.</p>
--	--

WHEREAS, the County Executive/Department of Public Works/ Division of County Engineer recommends awards on RQ12381 with various engineering firms in the total amount not-to-exceed \$1,350,000.00 for general engineering services, commencing upon contract signature of all parties for a period of three (3) years as follows:

- a) Contract No. 3585 with Chagrin Valley Engineering, Ltd. in the amount not-to-exceed \$450,000.00
- b) Contract No. 3586 with The Mannik & Smith Group, Inc. in the amount not-to-exceed \$450,000.00.
- c) Contract No. 3854 with Crawford, Murphy & Tilly, Inc. in the amount not-to-exceed \$450,000.00.

WHEREAS, the primary goal of this project is to perform general engineering services for roadway and bridge projects; and

WHEREAS, the project is funded by 100% Road and Bridge Fund; and

WHEREAS, it is necessary that this Resolution become immediately effective in order that critical services provided by Cuyahoga County can continue and to provide for the usual, daily operation of a County entity.

NOW, THEREFORE, BE IT RESOLVED BY THE COUNTY COUNCIL OF CUYAHOGA COUNTY, OHIO:

SECTION 1. That the Cuyahoga County Council hereby makes awards on RQ12381 with various engineering firms in the total amount not-to-exceed

\$1,350,000.00 for general engineering services, commencing upon contract signature of all parties for a period of three (3) years as follows:

- a) Contract No. 3585 with Chagrin Valley Engineering, Ltd. in the amount not-to-exceed \$450,000.00
- b) Contract No. 3586 with The Mannik & Smith Group, Inc. in the amount not-to-exceed \$450,000.00.
- c) Contract No. 3854 with Crawford, Murphy & Tilly, Inc. in the amount not-to-exceed \$450,000.00.

SECTION 2. That the County Executive is authorized to execute Contract Nos. 3585, 3586 & 3854 and all documents consistent with said awards and this Resolution. To the extent that any exemptions are necessary under the County Code and contracting procedures, they shall be deemed approved by the adoption of this Resolution.

SECTION 3. It is necessary that this Resolution become immediately effective for the usual daily operation of the County; the preservation of public peace, health or safety in the County; and any additional reasons set forth in the preamble. Provided that this Resolution receives the affirmative vote of at least eight members of Council, it shall take effect and be in force immediately upon the earliest occurrence of any of the following: (1) its approval by the County Executive through signature, (2) the expiration of the time during which it may be disapproved by the County Executive under Section 3.10(6) of the Cuyahoga County Charter, or (3) its passage by at least eight members of Council after disapproval pursuant to Section 3.10(7) of the Cuyahoga County Charter. Otherwise, it shall take effect and be in force from and after the earliest period allowed by law.

SECTION 4. It is found and determined that all formal actions of this Council relating to the adoption of this Resolution were adopted in an open meeting of the Council, and that all deliberations of this Council and of any of its committees that resulted in such formal action were in meetings open to the public, in compliance with all legal requirements, including Section 121.22 of the Ohio Revised Code.

On a motion by _____, seconded by _____, the foregoing Resolution was duly adopted.

Yeas:

Nays:

County Council President

Date

County Executive

Date

Clerk of Council

Date

First Reading/Referred to Committee: July 18, 2023

Committee(s) Assigned: Public Works, Procurement & Contracting

Journal _____
_____, 20____

Public Works, 2023, Submit & Award Contracts with Crawford, Murphy & Tilly, Inc., Chagrin Valley Engineering, LTD, & The Mannik & Smith Group, Inc. for General Engineering Services for Roadway and Bridge - RFQ#12381 - \$1,350,000

Scope of Work Summary:

Department of Public Works is requesting to submit and award the contract agreements with Crawford, Murphy & Tilly, Inc., Chagrin Valley Engineering, LTD, & The Mannik & Smith Group, Inc. for the General Engineering Services for Roadway and Bridge in the amount of \$450,000 per contract.

The contract term is three years from the signature of all parties ("Effective Date").

The County has determined the need to engage these three consultants to perform the primary goal of General Engineering Services for Roadway and Bridge.

Procurement

The procurement method for this project was RFQ 12381. The total value of the RFQ was for \$1,350,000 with up to \$450,000 set aside for each vendor.

2a. The RFQ was closed on May 1, 2023

There were 15 proposals submitted for review, and three (3) proposals selected, one with Crawford, Murphy & Tilly, Inc., one with Chagrin Valley Engineering, LTD, (SBE Set-Aside) and one with The Mannik & Smith Group, Inc..

There was DEI aspirational goals of 20% SBE, 8% MBE, 2% WBE, and an SBE Set-Aside on this RFQ.

Consultant and Project Information

The addresses are:

Crawford, Murphy & Tilly, Inc.
6060 Rockside Woods Blvd. N., Suite 321
Independence, Ohio 44131

Chagrin Valley Engineering, LTD
22999 Forbes Rd., Suite B
Cleveland, Ohio 44146

The Mannik & Smith Group, Inc.
20600 Chagrin Blvd., Suite 500
Shaker Hts., Ohio 44122

The Crawford, Murphy & Tilly Project Manager is Scott Knebel (440) 462-4020.
The Chagrin Valley Engineering Project Manager is Beth Fulton (440) 439-1999.
The Mannik & Smith Group Vice President is Steve Bergman (216) 378-1490.

Project Status & Planning

This project is new to the County.

Funding

The project is funded by 100% County Road & Bridge fund. PW270205-73300
The schedule of payments is by invoice.

Department of Purchasing – Required Documents Checklist

Upload as “word” document in Infor

Infor/Lawson RQ#:	12381
Infor/Lawson PO# Code (if applicable):	RFQ
Event #	4291
CM Contract#	3584

	Department initials	Clerk of the Board
Briefing Memo	LW	<input type="checkbox"/>

Late Submittal Required:	Yes <input type="checkbox"/>	No <input type="checkbox"/>
Why is the contract being submitted late?		
What is being done to prevent this from reoccurring?		

TAC or CTO Required or authorized IT Standard	Yes <input type="checkbox"/>	No <input type="checkbox"/>
---	------------------------------	-----------------------------

FULL AND OPEN COMPETITION Formal RFQ Reviewed by Purchasing
--

	Department initials	Purchasing
Notice of Intent to Award (sent to all responding vendors)	LW	OK
Bid Specification Packet RFQ	LW	OK
Final DEI Goal Setting Worksheet	LW	OK
Diversity Documents – <i>if required (goal set)</i> See Vendor Submission	LW	OK
Award Letter (sent to awarded vendor)	LW	OK
Vendor’s Confidential Financial Statement – <i>if RFP requested</i>	N/A	N/A
Tabulation Sheet	LW	OK
Evaluation with Scoring Summary (<i>Names of evaluators to be included, must have minimum of three evaluators</i>).	LW	OK
IG# 22-0003 12/31/2026	LW	OK
Debarment/Suspension Verified Date: 6/22/23	LW	OK
Auditor’s Finding Date: 6/23/23	LW	OK
Vendor’s Submission	LW	OK
Independent Contractor (I.C.) Requirement Date: 6/16/23	LW	OK
Cover - <i>Master contracts only</i>	N/A	OK
Contract Evaluation – <i>if required</i>	N/A	N/A
TAC/CTO Approval or IT Standards (attach and identify relevant page #s), if required.	N/A	N/A
Checklist Verification	LW	OK

Other documentation may be required depending upon your specific item

Glossary of Terms at: <https://intranet.cuyahoga.cc/policies-procedures/procurement-information>

Reviewed by Law	
	Department initials
Agreement/Contract and Exhibits	LW
Matrix Law Screen shot	LW
COI	LW
Workers’ Compensation Insurance	LW

Department of Purchasing – Required Documents Checklist

Upload as “word” document in Infor

CONTRACT SPENDING PLAN

Time Period	Accounting Unit	Account	Activity	Account Category or Subaccount	Amount
Effective Date – 12/31/23	PW270205	73300			\$ 300,00 \$300,000.00
1/1/24 – 12/31/24	PW270205	73300			\$ 150,000
1/1/25 – 12/31/25	PW270205	73300			\$
1/1/26 – Three years from effective date	PW270205	73300			\$
			TOTAL		\$ 450,000

CONTRACT HISTORY (to be completed by department) New contract -no contract history

CE/AG# (if applicable)					
Infor/Lawson PO# and PO Code (if applicable)					
Lawson RQ# (if applicable) 12381					
CM Contract#					
	Original Amount	Amendment Amount	Original Time Period & End Date/ Amended End Date	Approval Date	Approval #
Original Amount	\$				
	Prior Amendment Amounts (list separately)	\$			
		\$			
		\$			
	Pending Amendment	\$			
	Total Amendments	\$			
Total Contact Amount	\$				

PURCHASING USE ONLY

Prior Resolutions	
CM#:	3584
Vendor Name:	Crawford, Murphy & Tilly, Inc.
ftp:	3 years, effective upon execution by both parties
Amount:	\$450,000.00mm
History/CE:	OK
EL:	OK
Procurement Notes:	6/29/2023: Award 1 of 3; notice of intent letter and award letter sent prior to DEI-completed tab sheet completion; evaluation scoring matrix shows all vendors being Diversity-compliant, this does not match the completed

Department of Purchasing – Required Documents Checklist

Upload as “word” document in Infor

	spreadsheet; Reviewed – will approve once all 3 award actions are reviewed/approved.
Purchasing Buyer’s initials and date of approval	OK, ssp 6/30/2023

Department of Purchasing – Required Documents Checklist

Upload as “word” document in Infor

Infor/Lawson RQ#:	12381
Infor/Lawson PO# Code (if applicable):	RFQ
Event #	4291
CM Contract#	3585

	Department initials	Clerk of the Board
Briefing Memo	LW	<input type="checkbox"/>

Late Submittal Required:	Yes <input type="checkbox"/>	No <input type="checkbox"/>
Why is the contract being submitted late?		
What is being done to prevent this from reoccurring?		

TAC or CTO Required or authorized IT Standard	Yes <input type="checkbox"/>	No <input type="checkbox"/>
---	------------------------------	-----------------------------

FULL AND OPEN COMPETITION

Formal RFQ

Reviewed by Purchasing

	Department initials	Purchasing
Notice of Intent to Award (sent to all responding vendors)	LW	OK
Bid Specification Packet RFQ	LW	OK
Final DEI Goal Setting Worksheet	LW	OK
Diversity Documents – <i>if required (goal set)</i> See Vendor Submission	LW	OK
Award Letter (sent to awarded vendor)	LW	OK
Vendor’s Confidential Financial Statement – <i>if RFP requested</i>	N/A	N/A
Tabulation Sheet	LW	OK
Evaluation with Scoring Summary (<i>Names of evaluators to be included, must have minimum of three evaluators</i>).	LW	OK
IG# 20-0124 12/31/2024	LW	OK
Debarment/Suspension Verified Date: 6/22/23	LW	OK
Auditor’s Finding Date: 6/23/23	LW	OK
Vendor’s Submission	LW	OK
Independent Contractor (I.C.) Requirement Date: 6/16/23	LW	OK
Cover - <i>Master contracts only</i>	N/A	OK
Contract Evaluation – <i>if required</i>	N/A	OK
TAC/CTO Approval or IT Standards (attach and identify relevant page #s), if required.	N/A	N/A
Checklist Verification	LW	OK

Other documentation may be required depending upon your specific item

Glossary of Terms at: <https://intranet.cuyahoga.cc/policies-procedures/procurement-information>

Reviewed by Law

	Department initials
Agreement/Contract and Exhibits	LW
Matrix Law Screen shot	LW
COI	LW
Workers’ Compensation Insurance	LW

1 | Page

Revised 7/28/2022

Department of Purchasing – Required Documents Checklist

Upload as “word” document in Infor

CONTRACT SPENDING PLAN

Time Period	Accounting Unit	Account	Activity	Account Category or Subaccount	Amount
Effective Date – 12/31/23	PW270205	73300			\$ 300,00 \$300,000.00
1/1/24 – 12/31/24	PW270205	73300			\$ 150,000
1/1/25 – 12/31/25	PW270205	73300			\$
1/1/26 – Three years from effective date	PW270205	73300			\$
			TOTAL		\$ 450,000

CONTRACT HISTORY (to be completed by department)

CE/AG# (if applicable)					
Infor/Lawson PO# and PO Code (if applicable)					
Lawson RQ# (if applicable)		4442			
CM Contract#		1289			
	Original Amount	Amendment Amount	Original Time Period & End Date/ Amended End Date	Approval Date	Approval #
Original Amount	\$ 450,000		7/6/21 – 7/5/24	6-8-21	R2021-0137
	Prior Amendment Amounts (list separately)	\$			
	Pending Amendment	\$			
	Total Amendments	\$			
Total Contact Amount	\$ 450,000				

PURCHASING USE ONLY

Prior Resolutions	R2021-0137
CM#:	3585
Vendor Name:	Chagrin Valley Engineering, Ltd.
ftp:	3 years, effective upon execution by both parties
Amount:	\$450,000.00mm
History/CE:	OK
EL:	OK
Procurement Notes:	6/29/2023: Award 2 of 3; notice of intent letter and award letter sent prior to DEI-completed tab sheet completion; evaluation scoring matrix shows all vendors being Diversity-compliant, this does not match the completed

Department of Purchasing – Required Documents Checklist

Upload as “word” document in Infor

	spreadsheet; Reviewed – will approve once all 3 award actions are reviewed/approved.
Purchasing Buyer’s initials and date of approval	OK, ssp 6/30/2023

Department of Purchasing – Required Documents Checklist

Upload as “word” document in Infor

Infor/Lawson RQ#:	12381
Infor/Lawson PO# Code (if applicable):	RFQ
Event #	4291
CM Contract#	3586

	Department initials	Clerk of the Board
Briefing Memo	LW	<input type="checkbox"/>

Late Submittal Required:	Yes <input type="checkbox"/>	No <input type="checkbox"/>
Why is the contract being submitted late?		
What is being done to prevent this from reoccurring?		

TAC or CTO Required or authorized IT Standard	Yes <input type="checkbox"/>	No <input type="checkbox"/>
---	------------------------------	-----------------------------

FULL AND OPEN COMPETITION Formal RFQ Reviewed by Purchasing
--

	Department initials	Purchasing
Notice of Intent to Award (sent to all responding vendors)	LW	OK
Bid Specification Packet RFQ	LW	OK
Final DEI Goal Setting Worksheet		OK
Diversity Documents – <i>if required (goal set)</i> See Vendor Submission	LW	OK
Award Letter (sent to awarded vendor)	LW	OK
Vendor’s Confidential Financial Statement – <i>if RFP requested</i>	N/A	N/A
Tabulation Sheet	LW	OK
Evaluation with Scoring Summary (<i>Names of evaluators to be included, must have minimum of three evaluators.</i>)	LW	OK
IG# 12-2740 12/31/2023	LW	OK
Debarment/Suspension Verified Date: 6/22/23	LW	OK
Auditor’s Finding Date: 6/23/23	LW	OK
Vendor’s Submission	LW	OK
Independent Contractor (I.C.) Requirement Date: 6/23/23	LW	OK
Cover - <i>Master contracts only</i>	N/A	OK
Contract Evaluation – <i>if required</i>	N/A	N/A
TAC/CTO Approval or IT Standards (attach and identify relevant page #s), if required.	N/A	N/A
Checklist Verification	LW	OK

Other documentation may be required depending upon your specific item

Glossary of Terms at: <https://intranet.cuyahoga.cc/policies-procedures/procurement-information>

Reviewed by Law	
	Department initials
Agreement/Contract and Exhibits	LW
Matrix Law Screen shot	LW
COI	LW
Workers’ Compensation Insurance	LW

Department of Purchasing – Required Documents Checklist

Upload as “word” document in Infor

CONTRACT SPENDING PLAN

Time Period	Accounting Unit	Account	Activity	Account Category or Subaccount	Amount
Effective Date – 12/31/23	PW270205	73300			\$ 300,000
1/1/24 – 12/31/24	PW270205	73300			\$ 150,000
1/1/25 – 12/31/25	PW270205	73300			\$
1/1/26 – Three years from effective date	PW270205	73300			\$
			TOTAL		\$ 450,000

CONTRACT HISTORY (to be completed by department) New contract -no contract history

CE/AG# (if applicable)					
Infor/Lawson PO# and PO Code (if applicable)					
Lawson RQ# (if applicable)		12381			
CM Contract#		3586			
	Original Amount	Amendment Amount	Original Time Period & End Date/ Amended End Date	Approval Date	Approval #
Original Amount	\$				
	Prior Amendment Amounts (list separately)	\$			
		\$			
		\$			
	Pending Amendment	\$			
	Total Amendments	\$			
Total Contact Amount	\$				

PURCHASING USE ONLY

Prior Resolutions	
CM#:	3586
Vendor Name:	The Mannik & Smith Group, Inc.
ftp:	3 years, effective upon execution by both parties
Amount:	\$450,000.00mm
History/CE:	OK
EL:	OK
Procurement Notes:	6/30/2023: Contract uploaded 6/29/2023: Award 3 of 3; notice of intent letter and award letter sent prior to DEI-completed tab sheet completion; evaluation scoring matrix shows all vendors being Diversity-compliant, this does not match the completed spreadsheet; e-mail to Lisa to delete/re-upload signed contract

2 | Page

Revised 7/28/2022

Department of Purchasing – Required Documents Checklist

Upload as “word” document in Infor

Purchasing Buyer’s initials and date of approval	OK, ssp 6/30/2023
---	-------------------



Department of Purchasing Tabulation Sheet

REQUISITION NUMBER: 12381	EVENT: 4291	TYPE: RFQ	ESTIMATE: \$1,350,000.00
CONTRACT PERIOD: 3-year contract	RFQ DUE DATE: May 31, 2023	NUMBER OF RESPONSES (issued/submitted): 109/15	
REQUESTING DEPARTMENT: Public Works	COMMODITY DESCRIPTION: 2023 General Engineering Services		
Non Set-Aside DIVERSITY GOAL/SBE 20%	Non Set-Aside DIVERSITY GOAL/MBE 8%	Non Set-Aside DIVERSITY GOAL/WBE 2%	
Set-Aside DIVERSITY GOAL/SBE Prime	Set-Aside DIVERSITY GOAL/MBE 8%	Set-Aside DIVERSITY GOAL/WBE 2%	

Bidder's / Vendors Name and Address	Buyer Administrative Review:	Diversity Program Review:	Dept. Tech. Review	Award: (Y/N)
<p>1. 2LMN, Inc. 1422 Euclid Avenue Suite 1044 Cleveland, Ohio 44115</p>	<p>Compliant: <input checked="" type="checkbox"/> Yes</p> <p>IG Registration Complete: <input checked="" type="checkbox"/> Yes IG Number: 23-0158</p> <p>Planholder: <input checked="" type="checkbox"/> Yes</p> <p>Department of Purchasing: SSP</p>	<p>SBE / MBE / WBE</p> <p>Subcontractor Name(s): (MAPA) 2LMN, Inc SBE/MBE 20% (MAPA) DLZ Ohio, Inc. MBE 5% (FV) Lawhon & Associates, Inc. SBE/WBE 5% (MAPA) Barr Engineering, Inc. DBA National Engineering & Architecture, Inc. SBE/MBE 2%</p> <p>SBE/MBE/WBE Prime: (Y/N) <input checked="" type="checkbox"/> Yes <input checked="" type="checkbox"/> SBE <input checked="" type="checkbox"/> MBE <input type="checkbox"/> WBE <input type="checkbox"/> No</p> <p>Total % SBE Set Aside Prime - SBE: _____ Prime MBE: 7 % WBE: 5 % Non SBE Set Aside - SBE: 20 % MBE: 7 % WBE: 5 %</p>		<p><input type="checkbox"/> Yes <input checked="" type="checkbox"/> No</p>

Bidder's / Vendors Name and Address	Buyer Administrative Review:	Diversity Program Review:		Dept. Tech. Review	Award: (Y/N)
		SBE / MBE / WBE SBE/MBE/WBE Comply: (Y/N)	<input checked="" type="checkbox"/> Yes LL 6/9/23 <input type="checkbox"/> No		
2. AECOM Services of Ohio 1300 East 9 th Street Suite 500 Cleveland, Ohio 44114	Compliant: <input checked="" type="checkbox"/> Yes IG Registration Complete: <input checked="" type="checkbox"/> Yes IG Number: 20-0215 Planholder: <input checked="" type="checkbox"/> Yes Department of Purchasing: SSP	SBE/MBE/WBE Comments and Initials:	No DIV 2 completed for Prime. -ss 6/5/23 Prime selected 7%MBE Participation, diversity goal 8%, no good faith effort div-3 provided for waiver, prime provided county certified certificate and letter for subcontractors JW 6/8/2023If top ranked/selected, dept should attempt to negotiate vendor into compliance for MBE goal of 8%. Otherwise, based on proposed 7% and lack of DIV-3 documenting good faith effort to achieve MBE Goal, vendor is non-compliant. LL 6/9/23.		<input type="checkbox"/> Yes <input checked="" type="checkbox"/> No

RQ12381

Bidder's / Vendors Name and Address	Buyer Administrative Review:	Diversity Program Review: SBE / MBE / WBE	Dept. Tech. Review	Award: (Y/N)
		<p><input type="checkbox"/> Yes <input type="checkbox"/> SBE <input type="checkbox"/> MBE <input type="checkbox"/> WBE <input checked="" type="checkbox"/> No</p> <p>SBE/MBE/WBE Prime: (Y/N)</p> <p>Total %</p> <p>SBE SetAside Prime - SBE: <u> </u> N/A Prime 20% MBE: <u>8 %</u> WBE: <u>2 %</u> Non SBE Set Aside - SBE: <u>20 %</u> MBE: <u>8 %</u> WBE: <u>2 %</u></p> <p>SBE/MBE/WBE Comply: (Y/N) <input type="checkbox"/> Yes <input checked="" type="checkbox"/> No LL 6/9/2023</p> <p>SBE/MBE/WBE Comments and Initials: No scope of work completed for Charles P. Braman & Co., Inc. or Vavro Conservation Services, LLC -ss 06/05/23 Prime provided county certified certificate and letter for subcontractors JW 6/8/2023 LL 6/9/2023 Not eligible for SBE Set Aside. For Non-SBE Set Aside, we need DIV-2 forms to detail scope of work to be subcontracted to the above detailed vendors. LL 6/9/2023</p>		

Bidder's / Vendors Name and Address	Buyer Administrative Review:	Diversity Program Review:	Dept. Tech. Review	Award: (Y/N)
<p>3. Arcadis U.S., Inc. 1111 Superior E. Suite 1300 Cleveland, Ohio 44114</p>	<p>Compliant: <input checked="" type="checkbox"/> Yes IG Registration Complete: <input checked="" type="checkbox"/> Yes IG Number: 12-0526 Planholder: <input checked="" type="checkbox"/> Yes Department of Purchasing: SSP</p>	<p>SBE / MBE / WBE</p> <p>Subcontractor Name(s): (MAPA) 2LMN, Inc SBE/MBE 4% (MW) Chagrin Valley Engineering, LTD SBE 20% (MAPA) Pro Geotech, Inc. SBE/MBE 4% (FW) Lawhon & Associates, Inc. SBE/WBE 2%</p> <p>SBE/MBE/WBE Prime: (Y/N) <input type="checkbox"/> Yes <input type="checkbox"/> SBE <input type="checkbox"/> MBE <input type="checkbox"/> WBE <input checked="" type="checkbox"/> No</p> <p>Total % SBE Set Aside Prime - SBE: <u>N/A</u> Prime+20 % MBE: <u>8%</u> WBE: <u>2 %</u> Non SBE Set Aside - SBE: <u>20 %</u> MBE: <u>8%</u> WBE: <u>2 %</u></p> <p>SBE/MBE/WBE Comply: (Y/N) <input type="checkbox"/> Yes <input checked="" type="checkbox"/> No LL 6/9/2023</p> <p>SBE/MBE/WBE Comments and Initials: No comments. -ss 06/05/23 No div-1 provided, prime provided county certified certificate and letter for subcontractors, JW 6/8/2023 DIV-1 (completed and signed) needed. LL 6/9/2023</p>		<p><input type="checkbox"/> Yes <input checked="" type="checkbox"/> No</p>

	Bidder's / Vendors Name and Address	Buyer Administrative Review:	Diversity Program Review:	Dept. Tech. Review	Award: (Y/N)
4.	Chagrin Valley Engineering, LTD. 22999 Forbes Road Suite B Cleveland, Ohio 44146	Compliant: <input checked="" type="checkbox"/> Yes IG Registration Complete: <input checked="" type="checkbox"/> Yes IG Number: 20-0124 Planholder: <input checked="" type="checkbox"/> Yes Department of Purchasing: SSP	SBE / MBE / WBE Subcontractor Name(s): (MW) Chagrin Valley Engineering, Ltd. SBE 5% (FW) Lawhon & Associates, Inc. SBE/WBE 2% (MW) Euthenics, Inc. SBE 15% (MAPA) CTL Engineering, Inc. MBE 8% SBE/MBE/WBE Prime: (Y/N) <input checked="" type="checkbox"/> Yes <input checked="" type="checkbox"/> SBE <input type="checkbox"/> MBE <input type="checkbox"/> WBE <input type="checkbox"/> No Total % SBE SetAside Prime - SBE: Prime+15% MBE: 8 % WBE: 2 % Non SBE Set Aside - SBE: 35 % MBE: 8 % WBE: 2 % SBE/MBE/WBE Comply: (Y/N) <input checked="" type="checkbox"/> Yes LL 6/9/2023 <input type="checkbox"/> No SBE/MBE/WBE Comments and Initials: No comments -ss 06/05/2023 Prime completed diversity goals, no div-3 good faith effort provided, prime provided county certified certificate and letter for subcontractors, JW 6/8/2023 LL 6/9/2023		<input checked="" type="checkbox"/> Yes <input type="checkbox"/> No

	Bidder's / Vendors Name and Address	Buyer Administrative Review:	Diversity Program Review:	Dept. Tech. Review	Award: (Y/N)
5.	Crawford, Murphy & Tilly 6060 Rockside Woods Boulevard N. Suite 321 Independence, Ohio 44131	Compliant: <input checked="" type="checkbox"/> Yes IG Registration Complete: <input checked="" type="checkbox"/> Yes IG Number: 22-0003 Planholder: <input checked="" type="checkbox"/> Yes Department of Purchasing: SSP	<p>SBE / MBE / WBE</p> <p>Subcontractor Name(s): (MW) Euthenics, Inc. SBE 20% (MAPA) DLZ Ohio, Inc. MBE 8% (FW) CAD Concepts, Inc. dba CCI SBE/WBE 2%</p> <p>SBE/MBE/WBE Prime: (Y/N) <input type="checkbox"/> Yes <input type="checkbox"/> SBE <input type="checkbox"/> MBE <input type="checkbox"/> WBE <input checked="" type="checkbox"/> No</p> <p>Total % SBE Set Aside Prime - SBE: <u>N/A</u> Prime+20 % MBE: <u>8 %</u> WBE: <u>2 %</u> Non SBE Set Aside - SBE: <u>20 %</u> MBE: <u>8 %</u> WBE: <u>2 %</u></p> <p>SBE/MBE/WBE Comply: (Y/N) <input checked="" type="checkbox"/> Yes LL 6/9/2023 Non-SBE Set Aside <input type="checkbox"/> No</p> <p>SBE/MBE/WBE Comments and Initials: A DIV-2 was completed for Ohio Valley Archeology, Inc., they are not certified with Cuyahoga County. -ss 06/05/23 Prime provided county certified certificate and letter for subcontractors, JW 6/8/2023 LL 6/9/2023</p>		<input checked="" type="checkbox"/> Yes <input type="checkbox"/> No

Bidder's / Vendors Name and Address	Buyer Administrative Review:	Diversity Program Review:	Dept. Tech. Review	Award: (Y/N)
<p>6. DLZ, Inc 4208 Prospect Avenue Cleveland, Ohio 44103</p>	<p>Compliant: <input checked="" type="checkbox"/> Yes IG Registration Complete: <input checked="" type="checkbox"/> Yes IG Number: 12-1123 Planholder: <input checked="" type="checkbox"/> Yes Department of Purchasing: SSP</p>	<p>SBE / MBE / WBE</p> <p>Subcontractor Name(s): (MAPA) DLZ Ohio, Inc. MBE 20% (MW) Chagrin Valley Engineering, Ltd. SBE 24% (FW) Lawhon & Associates, Inc. SBE/WBE 3% (MAPA) Pro Geotech, Inc. SBE/MBE 3% (FW) Charles P. Braman & Co., Inc. SBE/WBE 2%</p> <p>SBE/MBE/WBE Prime: (Y/N) <input checked="" type="checkbox"/> Yes <input type="checkbox"/> SBE <input checked="" type="checkbox"/> MBE <input type="checkbox"/> WBE <input type="checkbox"/> No</p> <p>Total % SBE Set Aside Prime - SBE: <u>Prime+24</u> % MBE: <u>3</u> % WBE: <u>5</u> % Non SBE Set Aside - SBE: <u>24</u> % MBE: <u>23</u> % WBE: <u>5</u> %</p> <p>SBE/MBE/WBE Comply: (Y/N) <input checked="" type="checkbox"/> Yes <input type="checkbox"/> LL Non-SBE Set Aside (see below) <input type="checkbox"/> No</p> <p>SBE/MBE/WBE Comments and Initials: Prime awarded themselves 67% Incomplete DIV 2 for prime. -ss 06/05/23 Prime vendor only allowed up to 20% in one category, 67% changed to 20%, prime provided county certified certificate and letter for subcontractors. JW 6/8/2023 For</p>		<p><input type="checkbox"/> Yes <input checked="" type="checkbox"/> No</p>

Bidder's / Vendors Name and Address	Buyer Administrative Review:	Diversity Program Review: SBE / MBE / WBE	Dept. Tech. Review	Award: (Y/N)
		<p>SBE Set Aside, Prime vendor can only fulfill the SBE Prime requirement and, thus is lacking the MBE goal. For the Non-SBE Set Aside, they are lacking the MBE participation and DIV-3 submitted documenting good faith effort to achieve the MBE Goal. LL 6/9/2023</p>		

7. HDR Engineering, Inc. 600 Superior Avenue Suite 1700 Cleveland, Ohio 44114	<p>Compliant: <input checked="" type="checkbox"/> Yes</p> <p>IG Registration Complete: <input checked="" type="checkbox"/> Yes IG Number: 20-0304</p> <p>Planholder: <input checked="" type="checkbox"/> Yes</p> <p>Department of Purchasing: SSP</p>	<p>Subcontractor Name(s):</p> <p>(MAPA) 2LMN, Inc SBE/MBE 20% (MAPA) Barr Engineering, Inc. DBA National Engineering & Architecture, Inc. SBE/MBE 8% (FW) Lawhon & Associates, Inc. SBE/WBE 2%</p> <p>SBE/MBE/WBE Prime: (Y/N) <input type="checkbox"/> Yes <input type="checkbox"/> SBE <input type="checkbox"/> MBE <input type="checkbox"/> WBE <input checked="" type="checkbox"/> No</p> <p>Total %</p> <p>SBE SetAside Prime - SBE: <u>N/A</u> Prime+20 % MBE: <u>8 %</u> WBE: <u>2 %</u> Non SBE Set Aside - SBE: <u>20 %</u> MBE: <u>8 %</u> WBE: <u>2 %</u></p>		<input type="checkbox"/> Yes <input checked="" type="checkbox"/> No
---	---	--	--	--

8.	<p>HNTB Ohio, Inc. 1100 Superior Avenue Suite 1701 Cleveland, Ohio 44114</p>	<p>Compliant: <input checked="" type="checkbox"/> Yes IG Registration Complete: <input checked="" type="checkbox"/> Yes IG Number: 21-0328 Planholder: <input checked="" type="checkbox"/> Yes Department of Purchasing: SSP</p>	<p>SBE/MBE/WBE Comply: (Y/N)</p>	<p><input checked="" type="checkbox"/> Yes I.L. 6/9/2023 Non SBE Set Aside <input type="checkbox"/> No</p>	
<p>Subcontractor Name(s):</p> <p>(FW) ASC Group, Inc. SBE/WBE 5% (MW) Chagrin Valley Engineering, Ltd. SBE 20% (MAPA) Barr Engineering, Inc. DBA National Engineering & Architecture, Inc. SBE/MBE 10%</p>			<p>SBE/MBE/WBE Prime: (Y/N)</p>	<p>No comments. -ss 06/05/23 Prime provided county certified certificate and letter for subcontractors, no div-3 completed per vendor satisfied diversity goals, JW 6/8/2023 I.L. 6/9/2023</p>	
<p>Total %</p>			<p><input type="checkbox"/> Yes <input type="checkbox"/> SBE <input type="checkbox"/> MBE <input type="checkbox"/> WBE <input checked="" type="checkbox"/> No</p>	<p>SBE Set Aside Prime - SBE: <u>N/A</u> Prime+20 % MBE: <u>10 %</u> WBE: <u>5 %</u> Non SBE Set Aside - SBE: <u>20 %</u> MBE: <u>10 %</u> WBE: <u>5 %</u></p>	<p><input type="checkbox"/> Yes <input checked="" type="checkbox"/> No</p>

	<input checked="" type="checkbox"/> Yes LL 6/9/2023 Non-SBE Set Aside <input type="checkbox"/> No						<input checked="" type="checkbox"/> Yes <input type="checkbox"/> No
SBE/MBE/WBE Comply: (Y/N)	SBE/MBE/WBE Comments and Initials: No comments. -ss 06/05/23 Prime provided county certified certificate and letter for subcontractors, no div-3 completed per vendor satisfied diversity goals, JW 6/8/2023 LL 6/9/2023						
Subcontractor Name(s):				(MW) Chagrin Valley Engineering, Ltd. SBE 20% (MAPA) Barr Engineering, Inc. DBA National Engineering & Architecture, Inc. SBE/MBE 8% (FW) KS Associates, Inc. SBE/WBE 2% (MW) Euthenics, Inc. SBE 2%			
SBE/MBE/WBE Prime: (Y/N)				<input type="checkbox"/> Yes <input type="checkbox"/> SBE <input type="checkbox"/> MBE <input type="checkbox"/> WBE <input checked="" type="checkbox"/> No			
Total %				SBE SetAside Prime - SBE: <u> N/A </u> Prime+22 % MBE: <u> 8 % </u> WBE: <u> 2 % </u> Non SBE Set Aside - SBE: <u> 22 % </u> MBE: <u> 8 % </u> WBE: <u> 2 % </u>			

		<input checked="" type="checkbox"/> Yes LL 6/9/2023 Non-SBE Set Aside <input type="checkbox"/> No	
SBE/MBE/WBE Comply: (Y/N)	No comments. -ss 06/05/23 Prime provided county certified certificate and letter for subcontractors, no div-3 completed per vendor satisfied diversity goals, JW 6/8/2023 LL 6/9/2023		
SBE/MBE/WBE Comments and Initials:			

10.	Michael Baker International, Inc 1111 Superior Avenue E. Suite 2300 Cleveland, Ohio 44107	Compliant: <input checked="" type="checkbox"/> Yes IG Registration Complete: <input checked="" type="checkbox"/> Yes IG Number: 12-1898 Planholder: <input checked="" type="checkbox"/> Yes Department of Purchasing: SSP	Subcontractor Name(s): (MAPA) 2LMN, Inc SBE/MBE 4% (MW) Chagrin Valley Engineering, Ltd. SBE 20% (MAPA) Barr Engineering, Inc. DBA National Engineering & Architecture, Inc. SBE/MBE 4% (FW) Lawhon & Associates, Inc. SBE/WBE 2%	<input type="checkbox"/> Yes <input checked="" type="checkbox"/> No
-----	--	---	---	--

11.	ms consultants, inc. 425 Literary Road Suite 100 Cleveland, Ohio 44113	Compliant: <input checked="" type="checkbox"/> Yes IG Registration Complete: <input checked="" type="checkbox"/> Yes IG Number: 21-0305 Planholder: <input checked="" type="checkbox"/> Yes Department of Purchasing: SSP	<p>SBE/MBE/WBE Princ: (Y/N)</p> <p><input type="checkbox"/> Yes <input type="checkbox"/> SBE <input type="checkbox"/> MBE <input type="checkbox"/> WBE <input checked="" type="checkbox"/> No</p> <p>Total %</p> <p>SBE SetAside Prime - SBE: N/A Prime+20 % MBE: 8 % WBE: 2 % Non SBE Set Aside - SBE: 20 % MBE: 8 % WBE: 2 %</p> <p>SBE/MBE/WBE Comply: (Y/N)</p> <p><input checked="" type="checkbox"/> Yes LL 6/9/2023 Non-SBE Set Aside <input type="checkbox"/> No</p> <p>SBE/MBE/WBE Comments and Initials:</p> <p>No comments. -ss 06/05/23 Prime provided county certified certificate and letter for subcontractors, no div-3 completed per vendor satisfied diversity goals, JW 6/8/2023 LL 6/9/2023</p>		
			<p>Subcontractor Name(s):</p> <p>(MW) Euthenics, Inc. SBE 20% (MAPA) Barr Engineering, Inc. DBA National Engineering & Architecture, Inc. SBE/MBE 8% (FW) Charles P. Braman & Co., Inc. SBE/WBE 1% (FW) ASC Group, Inc. SBE/WBE 2% (MW) Smith & Nejedlik, Inc. SBE 1%</p>		<input type="checkbox"/> Yes <input checked="" type="checkbox"/> No

	<p>SBE/MBE/WBE Prime: (Y/N)</p> <p><input type="checkbox"/> Yes <input type="checkbox"/> SBE <input type="checkbox"/> MBE <input type="checkbox"/> WBE</p> <p><input checked="" type="checkbox"/> No</p>	<p>Total %</p> <p>SBE Set Aside Prime - SBE: N/A</p> <p>Prime+21 % MBE: <u>8</u> % WBE: <u>3</u> %</p> <p>Non SBE Set Aside - SBE: <u>21</u> %</p> <p>MBE: <u>8</u> % WBE: <u>3</u> %</p>	<p>SBE/MBE/WBE Comply: (Y/N)</p> <p><input checked="" type="checkbox"/> Yes LL 6/9/2023 Non-SBE Set Aside</p> <p><input type="checkbox"/> No</p>	<p>SBE/MBE/WBE Comments and Initials:</p> <p>No comments. -ss 06/05/23</p> <p>Prime provided county certified certificate and letter for subcontractors, no div-3 completed per vendor satisfied diversity goals. JW 6/8/2023 LL 6/9/2023</p>																																																																																																																																																																																																																																																																																																																																																																																																																																					

12.	<p>The Osborn Engineering Company 1111 Superior Avenue Suite 2100 Cleveland, Ohio 44114</p>	<p>Compliant: <input checked="" type="checkbox"/> Yes IG Registration Complete: <input checked="" type="checkbox"/> Yes IG Number: 20-0103 Planholder: <input checked="" type="checkbox"/> Yes Department of Purchasing: SSP</p>	<p>Subcontractor Name(s): (MW) Euthenics, Inc. SBE 20% (FW) Lawhon & Associates, Inc. SBE/WBE 2% MAPA) Barr Engineering, Inc. DBA National Engineering & Architecture, Inc. SBE/MBE %</p>	<p><input type="checkbox"/> Yes <input checked="" type="checkbox"/> No</p>
		<p>SBE/MBE/WBE Prime: (Y/N) <input type="checkbox"/> Yes <input type="checkbox"/> SBE <input type="checkbox"/> MBE <input type="checkbox"/> WBE <input checked="" type="checkbox"/> No</p>	<p>Total % SBE Set Aside Prime - SBE: <u>N/A</u> Prime+20 0% MBE: <u>0 %</u> WBE: <u>2 %</u> Non SBE Set Aside - SBE: <u>20 %</u> MBE: <u>0%</u> WBE: <u>2 %</u></p>	<p><input type="checkbox"/> Yes <input checked="" type="checkbox"/> No LL 6/9/2023</p>
		<p>SBE/MBE/WBE Comments and Initials:</p>	<p>Prime did not provide scope of work, dollar amount or percent of total overall contract for Barr Engineering Inc. DBA National Engineering & Architectural Services, Inc. -ss 06/05/23 Barr Engineering Inc. DBA National Engineering & Architectural Services, Inc-Cuyahoga county certified as MBE/SBE signed Div-2, no scope of work our amount to be contracted provided.</p>	

		<p>Prime provided county certified certificate and letter for subcontractors, JW 6/8/2023 Lacking MBE participation. Need fully completed and signed DIV-2. No DIV-3 submitted documenting good faith effort to achieve MBE Goal. LL 6/9/2023</p>		<input type="checkbox"/> Yes <input checked="" type="checkbox"/> No
13.	<p>Palmer Engineering 3745 Medina Road Suite A Medina 44256</p>	<p>Compliant: <input checked="" type="checkbox"/> Yes IG Registration Complete: <input checked="" type="checkbox"/> Yes IG Number: 20-0239 Planholder: <input checked="" type="checkbox"/> Yes Department of Purchasing: SSP</p>	<p>Subcontractor Name(s): (MAPA) Barr Engineering, Inc. DBA National Engineering & Architecture, Inc. SBE/MBE 8% (MW) Euthenics, Inc. SBE 15% (FW) Lawhon & Associates, Inc. SBE/WBE 4.5% (FW) Charles P. Braman & Co., Inc. SBE/WBE 2% (MW) Smith & Nejedlik, Inc. SBE .5%</p>	
	<p>SBE/MBE/WBE Prime: (Y/N)</p>	<p><input type="checkbox"/> Yes <input type="checkbox"/> SBE <input type="checkbox"/> MBE <input type="checkbox"/> WBE <input checked="" type="checkbox"/> No</p>		
	<p>Total %</p>	<p>SBE Set Aside Prime - SBE: <u>N/A</u> Prime+20 % MBE: <u>8 %</u> WBE: <u>2 %</u> Non SBE Set Aside - SBE: <u>20 %</u> MBE: <u>8 %</u> WBE: <u>2 %</u></p>		

	<input checked="" type="checkbox"/> Yes LL 6/9/2023 Non-SBE Set Aside <input type="checkbox"/> No			<input type="checkbox"/> Yes <input checked="" type="checkbox"/> No
SBE/MBE/WBE Comply: (Y/N)	No comments. -ss 06/05/23 Prime provided county certified certificate and letter for subcontractors, JW 6/8/2023 LL 6/9/2023	Subcontractor Name(s): (MAPA) DLZ Ohio, Inc. MBE 8% (MAPA) Barr Engineering, Inc. DBA National Engineering & Architecture, Inc. SBE/MBE 20% (FW) Lawhon & Associates, Inc. SBE/WBE 2%	SBE/MBE/WBE Comply: (Y/N)	<input type="checkbox"/> Yes <input checked="" type="checkbox"/> No
SBE/MBE/WBE Comply: (Y/N)	SBE Set/Aside Prime - SBE: N/A Prime+20 % MBE: 8 % WBE: 2 % Non SBE Set Aside - SBE: 20 % MBE: 8 % WBE: 2 %	Total %	SBE/MBE/WBE Comply: (Y/N)	<input checked="" type="checkbox"/> Yes LL 6/9/2023 Non-SBE Set Aside <input type="checkbox"/> No
14. PRIME AE Group, Inc. 8415 Pulsar Place Suite 300 Columbus, Ohio 43240	Compliant: <input checked="" type="checkbox"/> Yes IG Registration Complete: <input checked="" type="checkbox"/> Yes IG Number: 22-0362 Planholder: <input checked="" type="checkbox"/> Yes Department of Purchasing: SSP			

<p>15. WSP USA Inc. 1660 West 2nd Street Suite 820 Cleveland, Ohio 44113</p>	<p>Compliant: <input checked="" type="checkbox"/> Yes IG Registration Complete: <input checked="" type="checkbox"/> Yes IG Number: 12-2159 Planholder: <input checked="" type="checkbox"/> Yes Department of Purchasing: SSP</p>	<p>SBE/MBE/WBE Comments and Initials: No comments. -ss 06/05/23 Prime provided county certified certificate and letter for subcontractors, JW 6/8/2023 LL 6/9/2023</p> <p>Subcontractor Name(s): (MW) Chagrin Valley Engineering, Ltd. SBE 20% (FW) KS Associates, Inc. SBE/WBE 2% (MAPA) Barr Engineering, Inc. DBA National Engineering & Architecture, Inc. SBE/MBE 8%</p> <p>SBE/MBE/WBE Prime: (Y/N) <input type="checkbox"/> Yes <input type="checkbox"/> SBE <input type="checkbox"/> MBE <input type="checkbox"/> WBE <input checked="" type="checkbox"/> No</p> <p>Total % SBE Set/Aside Prime - SBE: <u>N/A</u> Prime+20 % MBE: <u>8 %</u> WBE: <u>2 %</u> Non SBE Set Aside - SBE: <u>20 %</u> MBE: <u>8 %</u> WBE: <u>2 %</u></p> <p>SBE/MBE/WBE Comply: (Y/N) <input checked="" type="checkbox"/> Yes LL 6/9/2023 Non-SBE Set Aside <input type="checkbox"/> No</p>	<p><input type="checkbox"/> Yes <input checked="" type="checkbox"/> No</p>

County Council of Cuyahoga County, Ohio

Resolution No. R2023-0215

Sponsored by: County Executive Ronayne/Department of Public Works	A Resolution making an award on RQ12731 with R. L. Hill Management, Inc., in the amount not-to-exceed \$2,155,521.00 for construction of a multi-purpose room addition at the Cuyahoga County Animal Shelter; authorizing the County Executive to execute Contract No. 3588 and all other documents consistent with said award and this Resolution; and declaring the necessity that this Resolution become immediately effective.
--	---

WHEREAS, the County Executive/Department of Public Works recommends an award on RQ12731 with R. L. Hill Management, Inc., in the amount not-to-exceed \$2,155,521.00 for construction of a multi-purpose room addition at the Cuyahoga County Animal Shelter, effective upon contract signature of all parties; and

WHEREAS, the primary goal of this project is for the construction of a single story, slab on grade, structure of approximately 2,300 square feet as a multi-purpose room for training, meetings and other functions of the County Animal Shelter facility; and

WHEREAS, the anticipated start-completion dates are 9/12/2023 – 9/23/2024; and

WHEREAS, the project is funded by 66% General Fund and 34% Private Donation; and

WHEREAS, it is necessary that this Resolution become immediately effective in order that critical services provided by Cuyahoga County can continue and to provide for the usual, daily operation of a County entity.

NOW, THEREFORE, BE IT RESOLVED BY THE COUNTY COUNCIL OF CUYAHOGA COUNTY, OHIO:

SECTION 1. That the Cuyahoga County Council hereby makes an award on RQ12731 with R. L. Hill Management, Inc., in the amount not-to-exceed \$2,155,521.00 for construction of a multi-purpose room addition at the Cuyahoga County Animal Shelter, effective upon contract signature of all parties.

SECTION 2. That the County Executive is authorized to execute Contract No. 3588 and all other documents consistent with said award and this Resolution.

Department of Public Works Cuyahoga County Animal Shelter Multi-Purpose Room Addition.

Scope of Work Summary

The Department of Public Works is requesting approval of a contract with R.L. Hill Management Inc., Inc. for the anticipated cost of \$2,155,521.00.

The work is comprised of single story, slab on grade , structure of approximately 2,300 square feet as a multi-purpose room for training, meetings and other functions of the County Animal Shelter facility. This is an addition to the single-story structure completed in 2001. The construction involves an exposed steel structural frame, independent of the existing structural system. All structural members and building elements are exposed and painted. The roof is a low slope metal deck with insulation and modified bitumen roof covering. The underside of the roof deck is largely covered with prefinished acoustical panels for sound control. Exterior walls are designed to match the existing in material, color, and finish, with face brick, exterior insulation, and finish system (EIFS) and insulated curtainwall glazing systems All exterior and interior partitions are non-load-bearing masonry. A new backlit building sign is provided on the new primary façade, and a new entrance. The addition is designed with an independent rooftop HVAC unit and painted, exposed distribution ductwork, while plumbing and electrical provisions are tied to the existing infrastructure. Sitework modifications include expanded asphalt paving for parking and vehicular circulation, replacement of concrete sidewalks and curbs and landscaping to supplement and complement the existing site conditions as well as artificial turf for dog outdoor areas enclosed by fences and gates. Anticipated dates are 9/12/2023-9/23/2024.

The project is not mandated. This is to be performed at the Cuyahoga County Animal Shelter.

Procurement

The procurement method for this project was RFB. The total value of the RFB is \$2,155,521.00.

The RFB was closed on 6/26/2023. There is an SBE goal of SBE 5%, MBE 16% and WBE 9%. The vendor committed to 5.35% SBE 16% MBE and 6.26% WBE. They were deemed non-compliant by DEI for being short on the WBE requirement and for shortcomings in their DIV-3 documentation for Good Faith Effort. ALL BIDDERS ARE MBE CERTIFIED PRIME CONTRACTORS.

There were 3 bids pulled from OPD, 3 bids submitted for review, 1 bid selected. Non-DEI compliant bid is being recommended by Public Works due to the immediate need for this contract award at the Animal Shelter. An Administrative Reconsideration request has been submitted by the recommended bidder.

For this project the engineer's estimate was \$2,028,847.00, and this was over by 3.4%.

Contractor and Project Information

R.L. Hill Management, Inc.

31835 Aurora Road

Solon, OH 44139

Council District (6)

The president for the vendor is Raphael Hill.

The address or location of the project is: Cuyahoga County Animal Shelter.

The project is in Council District (6)

Project Status and Planning

The project is new to the County.

Funding

The project is funded (66% General Fund, 34% Private Donation). The schedule of payment is by invoice.

Department of Purchasing – Required Documents Checklist

Upload as “word” document in Infor

Infor/Lawson RQ#:	12731
Infor/Lawson PO# Code (if applicable):	
Event #	4442
CM Contract#	3588

	Department	Clerk of the Board
Briefing Memo	WB	

Late Submittal Required:	Yes <input type="checkbox"/>	No <input checked="" type="checkbox"/>
Why is the contract being submitted late?		
What is being done to prevent this from reoccurring?		

TAC or CTO Required or authorized IT Standard	Yes <input type="checkbox"/>	No <input checked="" type="checkbox"/>
---	------------------------------	--

FULL AND OPEN COMPETITION Construction Projects – Buildings Reviewed by Purchasing		
	Department initials	Purchasing
Notice of Intent to Award (sent to all responding vendors)	WB	CQ
Bid Specification Packet (<i>includes Legal Notice to Bidders</i>)	WB	CQ
Final DEI Goal Setting Worksheet	WB	CQ
Diversity Documents – <i>if required (goal set)</i>	WB	CQ
Award Letter (sent to awarded vendor)	WB	CQ
Vendor’s Confidential Financial Statement – <i>if RFB requested</i>	N/A	NA
Non-Collusion Affidavit	WB	CQ
Public Works Bid Results	WB	CQ
Tabulation Sheet SEE Tab Sheet	WB	CQ
Prevailing Wage Public Improvement Agreement	WB	CQ
Sales and Use Tax Construction Contract Exemption Form, <i>if applicable</i>	WB	CQ
Worktype Worksheets, <i>if applicable</i>	N/A	NA
SBE Worktype Worksheets, <i>if applicable</i>	N/A	NA
Drug Free Workplace, <i>if applicable</i>	N/A	NA
Project of Similar Complexity, <i>if applicable</i>	WB	
EEOC (Equal Employment Opportunity Commission), <i>if applicable</i>	N/A	NA
Prevailing Wage Determination Cover Letter (with Prevailing Wage Rate sheets)	WB	CQ
Other, <i>per those listed in the Project Manual - see: Article 3, Section B. 2. “Bid Proposal Shall Contain the Following Document; and “Supplements Cuyahoga County Form of Proposal”</i>	WB	CQ
IG# 20-0132REG 31DEC2024	WB	CQ

Department of Purchasing – Required Documents Checklist

Upload as “word” document in Infor

Debarment/Suspension Verified	Date:	6/30/23	WB	CQ
Auditor’s Finding	Date:	6/30/23	WB	CQ
Vendor’s Submission (<i>Form of Proposal</i>)			WB	CQ
Independent Contractor (I.C.) Requirement	Date:	6/30/23	WB	CQ
Contract Evaluation – <i>if required</i>			N/A	NA
TAC/CTO Approval or IT Standards (attach and identify relevant page #s), if required.			N/A	NA
Checklist Verification			WB	CQ

Other documentation may be required depending upon your specific item

Glossary of Terms at: <https://intranet.cuyahoga.cc/policies-procedures/procurement-information>

Reviewed by Law

	Department initials
Agreement/Contract and Exhibits	WB
Matrix Law Screen shot	WB
COI	WB
Workers’ Compensation Insurance	WB
Bid Guarantee & Contract Bond	WB

Accounting Units

Time Period	Accounting Unit	Account Number	Sub Account	Dollar Amount
9/12/2023 – 12/31/2023	PW600120	72100	CFKEN0000801	\$200,000.00
1-1/2024 – 9/23/2024	PW600120	72100	CFKEN0000801	\$1,955,521.00
			TOTAL	\$2,155,521.00

Purchasing Use Only:

Prior Resolutions:	NA
CM#	3588
Vendor Name:	R.L. Hill Management
Amount:	\$2,155,521.00
History/CE:	OK
EL:	OK
Procurement Notes:	
Purchasing Buyer’s initials and date of approval	CQ 7/3/2023



Department of Purchasing Tabulation Sheet

M. A. [Signature] 6/29/2023

REQUISITION NUMBER: 12731 Event: 4442	TYPE: (RFB/RFP/RFQ): RFB	ESTIMATE: \$2,028,847.00 10% = \$2,231,731.70
CONTRACT PERIOD:	RFB/RFP/RFQ DUE DATE: June 26, 2023	NUMBER OF RESPONSES (issued/submitted): 8/3
REQUESTING DEPARTMENT: Public Works	COMMODITY DESCRIPTION: Cuyahoga County Animal Shelter Multi-Purpose Room Addition	
DIVERSITY GOAL/SBE 5%	DIVERSITY GOAL/MBE 16%	DIVERSITY GOAL/WBE 9%
Does CCBB Apply: <input type="checkbox"/> Yes <input checked="" type="checkbox"/> No No – The low bidder is in Cuyahoga County LL 6/29/23	CCBB: Low Non-CCBB Bid\$: \$2,155,521.00	Add 2%, Total is: \$2,198,631.40
Does CCBEIP Apply: <input checked="" type="checkbox"/> Yes <input type="checkbox"/> No Yes – But No Impact – The low bidder is not certified as an “Inclusive Business” And there is not a bidder within 2% of the low bidder that is certified as an “Inclusive Business” in the CCBEIP LL 6/29/23	CCBEIP: Low Non-CCBEIP Bid \$: \$2,155,521.00	Add 2%, Total is: \$2,198,631.40
*PRICE PREFERENCE LOWEST BID REC'D \$2,155,521.00	RANGE OF LOWEST BID REC'D \$ \$1,000,001-\$3,000,000	Minus \$, =
PRICE PREF % & \$ LIMIT: (8%)\$172,441.68 (MAX \$210,000)	MAX SBE/MBE/WBE PRICE PREF \$2,327,962.60	DOES PRICE PREFERENCE APPLY? <input type="checkbox"/> Yes <input checked="" type="checkbox"/> No No – no compliant bidders LL 6/29/23

Bidder's / Vendors Name and Address	Bid Bond / Check	Actual Bid Amount (enter "N/A" if RFP or RFQ)	Buyer Administrative Review: Buyer Initials	Price Preference	CCBB / CCBEIP Registered	Diversity Program Review: SBE / MBE / WBE	Dept. Tech. Review	Award (Y/N)
1 R. L. Hill Management Inc 31835 Aurora Rd Solon OH 44139	100% Travellers Casualty & Surety Company of America	\$2,155,521.00	Compliant: <input checked="" type="checkbox"/> Yes <input type="checkbox"/> No IG Registration Complete: <input checked="" type="checkbox"/> Yes IG Number: 20-0132-REG NCA: <input checked="" type="checkbox"/> Yes PH: <input checked="" type="checkbox"/> Yes CCBB: <input checked="" type="checkbox"/> Yes Response: <input checked="" type="checkbox"/> Yes CCBEIP: <input checked="" type="checkbox"/> Yes Response: <input checked="" type="checkbox"/> Yes Proposal Form:	<input type="checkbox"/> Yes <input type="checkbox"/> No	CCBB <input type="checkbox"/> Yes <input checked="" type="checkbox"/> No CCBEIP <input type="checkbox"/> Yes <input checked="" type="checkbox"/> No	Subcontractor Name(s): (MAA) R.L Hill Management, Inc SBE/ MBE 10.20 % (FHA) Zscape, LLC SBE/MBE/WBE 2.69% (FW) Cuyahoga Fence, LLC SBE/WBE .87% (FW) Frank Novak & Sons, Inc WBE 3.57% (MW) Commerce Plumbing Company SBE 3.43% (FW) Royal Landscape Gardening, Inc SBE/WBE 1.05% SBE/MBE/WBE Prime: (Y/N) Total % SBE: 5.35% MBE: 16% WBE: 6.26%	Total Bid - \$2,155,521.00 A. Cover Letter <input checked="" type="checkbox"/> Yes <input type="checkbox"/> No B. List of Convictions or Fines <input checked="" type="checkbox"/> Yes <input type="checkbox"/> No C. Project Organization Chart <input checked="" type="checkbox"/> Yes <input type="checkbox"/> No D. Firm's Safety Record <input checked="" type="checkbox"/> Yes <input type="checkbox"/> No E. Firm's Compliance SBE Record <input checked="" type="checkbox"/> Yes <input type="checkbox"/> No F. Firm's Experience	<input checked="" type="checkbox"/> Yes <input type="checkbox"/> No MQR 4/29/2023

Transaction ID:

Bidder's / Vendors Name and Address	Bid Bond / Check	Actual Bid Amount (enter "N/A" if RFP or RFQ)	Buyer Administrative Review: Buyer Initials	Price Preference	CCBB / CCBEIP Registered	Diversity Program Review: SBE / MBE / WBE	Dept. Tech. Review	Award : (Y/N)
			<input checked="" type="checkbox"/> No* *Total bid not filled on proposal form Hazardous Materials: <input checked="" type="checkbox"/> Yes Electronic Signatures: <input checked="" type="checkbox"/> Yes Bid Bond: <input checked="" type="checkbox"/> Yes OPD Buyer Initials: LZ 6/27/2023			SBE/MBE/WBE Comply: (Y/N) <input type="checkbox"/> Yes <input checked="" type="checkbox"/> No LL 6/29/23 SBE/MBE/WBE Comment and Initials: No DIV-3 1 of 2. Prime submitted a div-2 for Schroeder Plastering, Inc they are not certified with Cuyahoga County. L.Lyons 6/29/23 Vendor did not achieve the WBE Goal. Div-3 page 1 is missing. However, details provided on the 2 nd pages of Div-3 details on who was contacted. No details on when the vendor were contacted was provided. No supporting documentation of outreach (i.e., no emails). Must assume Prime call vendors. Insufficient documentation of Good Faith Effort to achieve the diversification goals. LL 6/29/23	<input checked="" type="checkbox"/> Yes <input type="checkbox"/> No G. Firm's Project Management Reports <input checked="" type="checkbox"/> Yes <input type="checkbox"/> No H. Site Visit Photographs <input checked="" type="checkbox"/> Yes <input type="checkbox"/> No Contractor has successfully completed similar and larger work on other County facilities with very good performance, to include the progress Men's Shelter Expansion and COVID Building Modifications Program.	

Transaction ID:

Bidder's / Vendors Name and Address 2 Ozanne Construction Company Inc 1635 E 25th Street Cleveland OH 44114	Bid Bond / Check 100% Nationwide Mutual Insurance Company	Actual Bid Amount (enter "N/A" if RFP or RFQ) \$2,205,577.00	Buyer Administrative Review: OPD Buyer Initials Compliant: <input checked="" type="checkbox"/> Yes IG Registration Complete: <input checked="" type="checkbox"/> Yes IG Number: 12-2130-REG NCA: <input checked="" type="checkbox"/> Yes PH: <input checked="" type="checkbox"/> Yes CCBB: <input checked="" type="checkbox"/> Yes Response: <input checked="" type="checkbox"/> Yes CCBEIP: <input checked="" type="checkbox"/> Yes Response: <input checked="" type="checkbox"/> Yes	Price Preference <input type="checkbox"/> Yes <input type="checkbox"/> No	CCBB / CCBEIP Registered CCBB: <input checked="" type="checkbox"/> Yes <input type="checkbox"/> No CCBEIP: <input type="checkbox"/> Yes <input checked="" type="checkbox"/> No	Diversity Program Review: SBE / MBE / WBE Subcontractor Name(s): (MAA) Ozanne Construction Co, Inc. Total Bid - MBE, 16% \$2,205,577.00 (MW) North Coast Concrete, Inc SBE 9.79% A. Cover Letter <input checked="" type="checkbox"/> Yes <input type="checkbox"/> No (MAPA) Bidar Construction Company SBE/MBE 2.27% B. List of Convictions or Fines <input checked="" type="checkbox"/> Yes <input type="checkbox"/> No (FW) Castle Heating and Air, Inc SBE/WBE 2.69% C. Project Organization Chart <input type="checkbox"/> Yes <input checked="" type="checkbox"/> No (FW) Cuyahoga Fence, LLC SBE/WBE 0.85% D. Firm's Safety Record <input type="checkbox"/> Yes <input checked="" type="checkbox"/> No (FW) Frank Novak & Sons, Inc WBE .35% E. Firm's Compliance SBE Record <input checked="" type="checkbox"/> Yes <input type="checkbox"/> No (MAA) Petty group, LLC SBE/MBE 4.36% (MW) Commerce Plumbing Company SBE 3.14% (FHA) Zscape, LLC SBE/MBE/WBE .26% (MAPA) Gateway Electric Communications, Inc SBE/MBE 11.33%	Dept. Tech. Review	Award: (Y/N) <input type="checkbox"/> Yes <input checked="" type="checkbox"/> No
--	--	---	---	---	--	---	--------------------	--

Transaction ID:

Bidder's / Vendors Name and Address	Bid Bond / Check	Actual Bid Amount (enter "N/A" if RFP or RFQ)	Buyer Administrative Review: OPD Buyer Initials	Price Preference	CCBB / CCBEIP Registered	Diversity Program Review: SBE / MBE / WBE	Dept. Tech. Review	Award: (Y/N)
			Proposal Form: <input checked="" type="checkbox"/> Yes Hazardous Materials: <input checked="" type="checkbox"/> Yes Electronic Signatures: <input checked="" type="checkbox"/> Yes Bid Bond: <input checked="" type="checkbox"/> Yes OPD Buyer Initials: LZ 6/27/2023			SBE/MBE/WBE Prime: (Y/N) <input checked="" type="checkbox"/> Yes <input type="checkbox"/> SBE <input checked="" type="checkbox"/> MBE <input type="checkbox"/> WBE <input type="checkbox"/> No Total % SBE: <u>12.93%</u> MBE: <u>37.96%</u> WBE: <u>4</u> SBE/MBE/WBE Comply: (Y/N) <input type="checkbox"/> Yes <input checked="" type="checkbox"/> No LL 6/29/23 SBE/MBE/WBE Comments and Initials: Prime is certified as a MBE and is registered as a CCBB but did not complete a DIV-2. DIV-3 1 of 2 and of 2 in the bid packet but left blank L.Lyons 6/29/2023 Prime MBE credited of 20%. Vendor did not achieve the WBE Goal. Blank Div-3 submitted. Hence, no good faith effort documentation/details provided. Insufficient Good Faith Effort. LL 6/29/23	F. Firm's Experience <input checked="" type="checkbox"/> Yes <input type="checkbox"/> No G. Firm's Project Management Reports <input type="checkbox"/> Yes <input checked="" type="checkbox"/> No H. Site Visit Photographs <input type="checkbox"/> Yes <input checked="" type="checkbox"/> No Contractor has successfully completed work on other County facilities with satisfactory performance to include multiple phases of the Central Booking project within the Cuyahoga County	

Transaction ID:

Bidder's / Vendors Name and Address	Bid Bond / Check	Actual Bid Amount (enter "N/A" if RFP or RFQ)	Buyer Administrative Review: OPD Buyer Initials	Price Preference	CCBB / CCBEIP Registered	Diversity Program Review: SBE / MBE / WBE	Dept. Tech. Review	Award: (Y/N)
							Corrections Center and Justice Center complex.	

Bidder's / Vendors Name and Address	3 SONA Construction LLC 7122 Harvard Ave Cleveland OH 44105	Bid Bond / Check	100% Western Surety Company	Actual Bid Amount (enter "N/A" if RFP or RFQ)	\$2,211,000.00	Buyer Administrative Review: OPD Buyer Initials	Compliant: <input checked="" type="checkbox"/> Yes IG Registration Complete: <input checked="" type="checkbox"/> Yes IG Number: 20-0261-REG NCA: <input checked="" type="checkbox"/> Yes PH: <input checked="" type="checkbox"/> Yes CCBB: <input checked="" type="checkbox"/> Yes Response: <input checked="" type="checkbox"/> Yes CCBEIP: <input checked="" type="checkbox"/> Yes Response: <input checked="" type="checkbox"/> Yes Proposal Form:	Price Preference	<input type="checkbox"/> Yes <input type="checkbox"/> No	CCBB / CCBEIP Registered	CCBB <input checked="" type="checkbox"/> Yes <input type="checkbox"/> No CCBEIP <input checked="" type="checkbox"/> Yes <input type="checkbox"/> No	Diversity Program Review: SBE / MBE / WBE	(MAPA) Sona SBE/MBE 20% (MAIA) Miles Mechanical, Inc SBE/MBE 3.07% (FW) Frank Novak & Sons, Inc WBE 0.35%	Dept. Tech. Review	Total Bid - \$2,211,000.00 A. Cover Letter <input checked="" type="checkbox"/> Yes <input type="checkbox"/> No B. List of Convictions or Fines <input checked="" type="checkbox"/> Yes <input type="checkbox"/> No C. Project Organization Chart <input checked="" type="checkbox"/> Yes <input type="checkbox"/> No D. Firm's Safety Record <input checked="" type="checkbox"/> Yes <input type="checkbox"/> No E. Firm's Compliance SBE Record <input checked="" type="checkbox"/> Yes <input type="checkbox"/> No F. Firm's Experience	Award: (Y/N)	<input type="checkbox"/> Yes <input checked="" type="checkbox"/> No
-------------------------------------	---	------------------	-----------------------------	---	----------------	---	--	------------------	---	--------------------------	--	---	---	--------------------	--	--------------	--

Transaction ID:

Bidder's / Vendors Name and Address	Bid Bond / Check	Actual Bid Amount (enter "N/A" if RFP or RFQ)	Buyer Administrative Review: OPD Buyer Initials	Price Preference	CCBB / CCBEIP Registered	Diversity Program Review: SBE / MBE / WBE	Dept. Tech. Review	Award: (Y/N)
			<input checked="" type="checkbox"/> Yes Hazardous Materials: <input checked="" type="checkbox"/> Yes Electronic Signatures: <input checked="" type="checkbox"/> Yes Bid Bond: <input checked="" type="checkbox"/> Yes OPD Buyer Initials: LZ 6/27/2023			L.Lyons 6/29/2023 Vendor did not achieve SBE and WBE goals. On page of Div-3, vendor detailed outreach only one (1) vendor. On page 1 of 3, vendor did not detail reason for waiver request or check actions completed in an attempt to achieve the diversity goals. No additional supporting documentation (i.e., emails) provided. LL 6/29/23.	ce <input checked="" type="checkbox"/> Yes <input type="checkbox"/> No G. Firm's Project Management Reports <input checked="" type="checkbox"/> Yes <input type="checkbox"/> No H. Site Visit Photographs <input type="checkbox"/> Yes <input checked="" type="checkbox"/> No Contractor has provided adequate construction project management for the in-progress Elevator Modernization project for the Cuyahoga County Corrections Center Jail 2 elevators.	

Transaction ID:

